



DAVERSTEELS

DYWIDAG-SYSTEMS
INTERNATIONAL



DYWIDAG IBERIAN REGION

SPAIN - HEADQUARTERS

Avenida de la Industria, 4
Polígono Industrial "La Cantueña"
28947 Fuenlabrada (Madrid)
Phone +34 91 642 20 72
Email dywidag@dywidag-sistemas.com
Website www.dywidag-sistemas.com

PORTUGAL - SALES OFFICE

Rua D. Manuel I, 24-A
Quinta da Parreirinha
2695-003 Bobadela
Phone +351 21 892 28 90
Email dywidag@dywidag-sistemas.com
Website www.dywidag-systems.pt





Welsh National Assembly Building, Cardiff



Structural Tie Bar System DST520

Introduction

Daver Steels are specialist manufacturers of CE marked threaded bars for structural and architectural applications. We have been supplying tension rods since 1996 and can offer assistance to architects, designers and the end user.

The DST520 tie rod system is produced in carbon or stainless steel, both with characteristic yield strengths of 520N/mm². The DST520 system provides a technical solution to your tie rod requirements, and our knowledge facilitates the supply of bespoke engineered solutions.

For applications which require an aesthetically pleasing solution for compressive loads we have designed an architectural compression strut system which allows adjustment of the overall length. The compression strut system is covered by our CE marking and the design calculations are validated by consultant structural engineers.

We stock carbon and stainless steel, grade 10.9 bars which can be end or fully threaded, in lengths up to 12m. DSHT bars are available for applications requiring high strength, large diameter, long threaded bars such as holding down bolts, structural bolting or temporary works.

Our advanced in-house CNC machine shop provides a custom manufacturing capability, to compliment our standard system components. All our products are covered by CE marking and our rigorous quality policy.

Forks

Daver Steels uphold the highest standards with our investment cast carbon and stainless steel forks.

- Carbon steel forks supplied galvanised as standard for our carbon steel system
- Duplex forks supplied bright polished as standard for our stainless steel system
- Additional NDT can be performed on request, along with 3.2 certification and 100% NDT X-Ray test

Threads

All our threads are cold rolled and are suitable for dynamic applications to match our EXC4 status. The nature of a rolled thread gives greater fatigue resistance.

Spanner Flats

Tie bars can be supplied with spanner flats, but this is not as standard. To prevent brittle fracture spanner flats are applied after galvanising.

Bar

DST520 bar is a high strength steel ranging in diameters from 12mm to 100mm. Bars are available upto 12m in a single length (longer lengths available on request) and have metric threads applied by cold rolling the thread form onto the bar. Bar is available in both carbon and stainless steel grades.

Carbon Steel - Grade 520

- 520N/mm² yield stress
- High strength, weldable, structural steel 27J Charpy V at -20°C, as standard
- Stocked in 12m lengths with rolled metric threads to BS3643. Longer lengths are available on request.
- Can be supplied self colour, painted or galvanised

Stainless Steel - Grade 520

- 520N/mm² 0.2% yield stress
- High strength cold drawn 316 stainless steel or F51 duplex stainless steel, EU origin
- Stocked in 6m lengths with rolled metric threads to BS3643. Longer lengths are available on request
- Usually offered as a 'satin' equivalent finish

For areas of higher corrosion exposure bright polished F51 stainless steel tendons are recommended.



Ordsall Chord Railway Bridge, Manchester



Remote load monitoring pins



Spherical roller bearings fitted to connection plate



Tie Bar Arrangements

Bar Diameters & Properties

T1 Bar Properties

Grade 520 Carbon Steel Bar		M12	M16	M20	M24	M30	M36	M42	M48	M56	M64	M76	M90	M100
Yield stress (bar material)	kN	520	520	520	520	520	520	520	520	520	520	520	520	520
Yield load	kN	44	82	127	184	292	425	583	766	1056	1392	1999	2879	3605
Design load to EC3	kN	39	73	115	165	263	382	525	689	950	1252	1820	2631	3294
Nominal bar diameter	mm	12	15	19	22	28	34	39	45	52	60	72	85	97
Maximum single bar length	m	6	12	12	12	12	12	12	12	12	12	12	12	12

Grade 520 Stainless Steel Bar		M12	M16	M20	M24	M30	M36	M42	M48	M56
Yield stress (bar material)	kN	520	520	520	520	520	520	520	520	520
Yield load	kN	44	82	127	184	292	425	583	766	1056
Design load to EC3	kN	39	73	115	165	263	382	525	689	950
Nominal bar diameter	mm	11	15	19	22	28	34	39	45	52
Maximum single bar length	m	6+	6+	6+	6+	6+	6	6	6	6

Design load to EC3

$$N_{Rd} = \min \{ A \cdot f_y / \gamma_{M1}; 0.9 \cdot A_{net} \cdot f_u / \gamma_{M2} \}$$

as per EN1993-1 with partial factors $\gamma_{M0} = 1.1$ & $\gamma_{M2} = 1.25$

Please contact our technical team for more information

The options shown here are generic arrangements
Please contact us about bespoke solutions.

See Table 3 (page 12) to ensure that there is
sufficient adjustment for the application.

Fork - Fork

The simplest form of tendon comprises a bar with a
left hand and right hand threaded fork at opposite
ends. Once installed, the tendon can be adjusted in
length by turning the bar.

Fork - Turnbuckle - Fork

Generally, for longer length tendons where fork to
fork tendons do not give adequate length adjust-
ment or the overall length exceeds the maximum
single bar length. A turnbuckle gives +/- 50mm
adjustment for M20 and above.

Where excessive sag in a horizontal bar is
anticipated, a welded connection cleat can be
made to the turnbuckle for hanger and stay bars
to be connected. Longer turnbuckles can also be
machined, together with jacking lockcovers for
applications where the bars need to be stressed
after installation.

For applications requiring jacking, please specify on
your enquiry.



Surface Finishes



Self Colour

Galvanised

Shot Blast & Primed



Buenavista Footbridge, Toledo, Spain

The DST520 tie bar & compression strut system can be finished to suit specified requirements in the following grades.

Carbon Steel

We stock galvanised forks and fittings as standard for our carbon steel system. The following surface finishes are available:

- Shot blast and primed; painted piece small and reassembled for site top coat
- Galvanised; bar threads are brushed after galvanising in accordance with BS EN 1461 and fitting threads are cut after galvanising to ensure free running. Alternatively, bar threads can be applied after galvanising and cold zinc applied (Zinga).
NB: Due to the nature of the galvanising process, the visual finish of galvanised product is variable. If a high level of aesthetic finish is required, systems should be subsequently painted after a suitable primer has been applied.
- Galvanised and painted to customer specifications
- Self colour
- Powder coated (length restrictions)
- Thermal spray zinc acc to ISO 22063

Notes

- If shot blasting, painting or galvanising is performed by others, please ensure that all threads are protected. Daver Steels cannot accept any responsibility for free running of threads once treated by others.
- Due to the welding required on compression struts and their shape, it is not advised to supply galvanised. Thermal zinc spray or paint systems should be considered.
- DSHT bar is high strength quench and tempered steel, and therefore should not be galvanised

Stainless Steel

For our stainless steel system we stock bright polished forks, satin finished bar and fittings as standard. We can offer the following finishes upon request:

- Satin finish
 - forks - satin polished
 - locking thread covers & pins - fine machined
 - bar - 240 Grit machine finish
- Bright polished
 - forks & fittings hand polished to a bright finish
 - bar machined finish to a bright polish

Stainless steel is corrosion resistant. However it is not completely maintenance-free in all environments. For example in coastal, swimming pool and leisure environments stainless steel requires cleaning with a proprietary cleaner to remove light surface corrosion. The time interval between cleaning will be determined by the severity of the exposure.

The DST520 stainless steel system should only be used in a chlorine environment after full consideration of the associated risks of stress corrosion cracking.

Where stainless steel fittings are in contact with carbon steel, bi-metallic corrosion may take place under certain conditions. To prevent this isolation coatings and washers can be supplied for the pins on request.





New York Times Tower, USA

Site Requirements

- When installed, DST520 tension bars and compression struts must be within 0.5° alignment from the plane (Fig. 1).
- DST520 forks must be installed at each end in the same plane, forks cannot be at 90° and must be inline (Fig. 2).
- If there are concerns about the angular alignment on site, we can supply special forks, pins and connection plates which include spherical bearings to account for misalignment or movement during the service life of the tendon.

Site Installation

For rapid installation on site, DST520 tendons are pre-assembled in the factory and set to their nominal pin-to-pin length. The tendons are then ready for immediate incorporation into the structure and generally require no site assembly, saving valuable time. To install follow the steps below.

General

- connection plates should be manufactured in minimum grade S355J2 steel; for dimensional detail see pages 14 & 15.
- for external applications, corrosion protection is recommended (e.g. hot dip galvanizing, painting etc)
- assembly and adjustment of fittings should be performed when the system is straight and not heavily loaded (long lengths may require intermediate supports)
- pins are to be connected without impact or drifting
- pin set screws should be secured using Loctite or equivalent chemical locking compound after installation
- tendons longer than 12m will be split into transportable lengths and some site assembly will be required. Ensure all components are fitted to the bar and the nominal pin-to-pin length has been set
- during the assembly process, it is crucial that no threads are exposed after the lockcovers, this ensures there is adequate thread engagement for loadbearing, at least 1 x diameter of the thread.

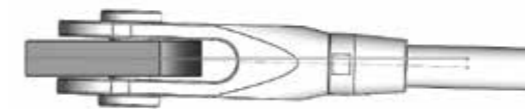

Fig 1. Fork alignment max 0.5°

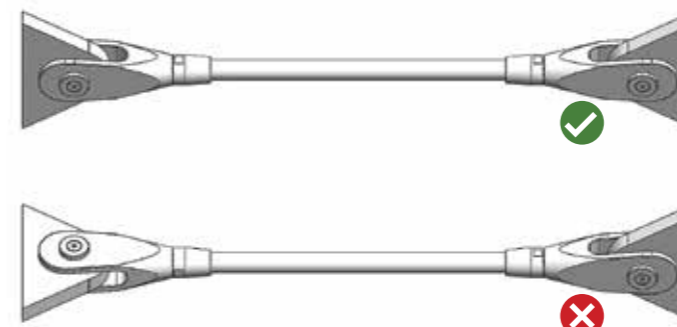

Fig 2. Forks must be installed in the same plane



Fig 3. Jacking turnbuckle arrangement with extra fittings

Site Stressing

Certain applications may require tendons to be stressed after installation. This can be performed provided jacking turnbuckles (Fig. 3) have been specified. Daver Steels offer a robust and easy-to-use range of jacking equipment to provide a simple solution to the stressing of tendons which can be performed by most competent steel erectors.

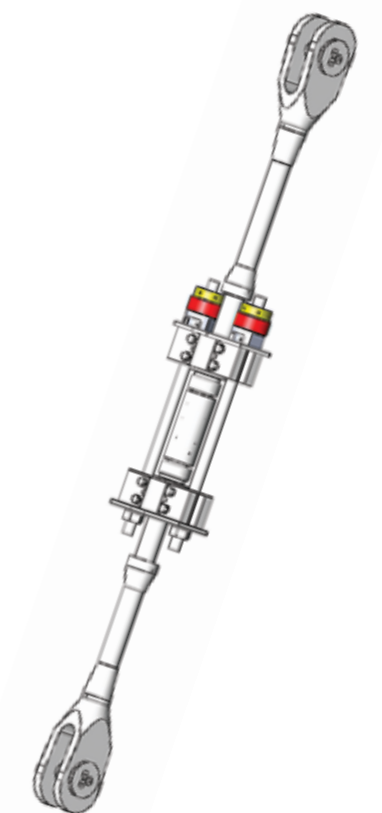



The Saddle Bar, Aintree Racecourse



English Institute of Sport, Sheffield



Peréz Art Museum, Miami, USA



Fatigue

Daver Steels routinely fatigue test complete tendons using standard parts to ensure the high performance of our system. Custom tests to suit the clients specific needs can be arranged. Below is a representative selection of some of our test results..

All tests have been carried out using standard DST520 forks, bars, pins and couplers/turnbuckles and have been conducted by calibrated labs at 4-5Hz frequency.

Final static load tests after the fatigue tests exceed our minimum stated break load capacities and have failed as designed - in the bar.

Plotting of the below results onto Figure 15 of BS5400 part 10 shows that Daver Steels DST520 bar system can be considered as being at least equivalent to class F for fatigue calculation purposes.

Size	Lower stress N/mm ²	Upper stress N/mm ²	Stress range N/mm ²	Cycles	Proof test at 90% UTS	Crack test pass	Final number cycles	Fatigue failure mode	Static break load kN
M42S	150	250	100	2 x 10 ⁶	Yes	Yes	2 x 10 ⁶	No failure	653
M56	228	314	86	3.53 x 10 ⁶	Yes	Yes	3.53 x 10 ⁶	No failure	1340
M56	199	314	114	2.16 x 10 ⁶	Yes	Yes	2.16 x 10 ⁶	No failure	1334
M85	188	292	104	2 x 10 ⁶	Yes	Yes	2 x 10 ⁶	No failure	3485
M90	188	292	104	2 x 10 ⁶	Yes	Yes	2 x 10 ⁶	No failure	3869

Quality System

Daver Steels (Bar & Cable Systems) Ltd are CE marked to BS EN 1090-1 up to EXC 4 for structural tie bar systems and high tensile bar, in stainless or carbon steel.

Compression struts can be supplied up to EXC 3 using our CE marked structural fabricators, and our calculations which are checked by consultant structural engineers.

We maintain a high level of quality with ISO 9001:2015 management system to ensure we meet our customers' high expectations.



Environment

The steel we use is produced from 90% recycled materials in an Electric Arc Furnace, with total carbon emissions 80% lower than the global average by investing in clean technologies and low fossil Nordic electricity. Green Clean Steel has less impurities, delivering a high quality steel with 2 tonnes less CO₂ per tonne of hot rolled steel. As with all steel, once our products reach their end of life they are 100% recyclable.



Fittings

Shown below are the standard range of Daver Steels fittings. Special fittings can be made and supplied upon request.



Standard centre disc



Custom centre connector



Fork end arrangement



Central Connectors

Centre discs are used to connect 3 or 4 tendons together at a central point. Bars and forks are generally threaded left hand/right hand for the central discs. Tendons are usually fork-fork type, but where longer adjustments or a pre-tension is required, fork-turnbuckle-fork arrangement can be used. Holes are drilled at an angle to suit your application whether for a braced bay or hanger rods.

- Standard centre discs are round with a central hole, but other shapes can be made on request



Fork Ends

Threaded fork ends are used to terminate bars and transfer load to the structure. Fork ends are cast components from M12 - M100. The forks are threaded left-hand or right-hand depending on the tie rod arrangement and are generally tapped with a blind hole for corrosion detailing.



Spade Ends

The spade design fits within the fork and matches the load criteria. Spades can be used in place of a fork but the effect of bending and single shear upon the pin must be taken into account. Spades are a special order item.



Pins

Standard pins are supplied as a pin barrel with end caps. The end caps are secured with countersunk socket set screws to provide a flush finish. Other pin details can be machined to your specific project requirements. M12 pins are of a headed design with circlip.

- Custom load monitoring solutions can be designed to suit your project requirements.

Lockcovers

The locking thread cover (lockcover) is a machined fitting which tapers the fork to the diameter of the bar. For the complete architectural look, they also hide exposed threads and when tightened against the fork and lock the tendon at the set length. Where thread covers are not required standard hexagonal nuts can be used.



Turnbuckles

Turnbuckles are left hand and right hand threaded bar connectors which allow in-situ length adjustments. These are machined with a central chamber to give greater length adjustment than can be achieved with the left-hand/right-hand fork combination.

- Jacking turnbuckles must be specified if you intend to tension large bars
- Custom length turnbuckles can be manufactured for extra adjustment



Cross Couplers

Cross couplers are available to provide a more cost-effective cross bracing solution than a centre disc, however the crossed bars limit the amount of adjustment available on site. Our standard cross couplers can accommodate a minimum of 40° between bars. Please contact our sales office for assistance with more acute angles.



Givatayim Bridge, Israel

Product Data

Fittings Design Data

A variety of fittings can be supplied to match your requirements. All fittings are designed to the requirements of BS5950. All fittings exceed the capacity of the bar. Fittings are supplied self colour, painted, galvanised or in stainless steel (satin or bright polished).

T2 Fork and Spade Assembly Dimensions

		M12	M16	M20	M24	M30	M36	M42	M48	M56	M64	M76	M90	M100
Nominal bar diameter		12	16	19	22	28	34	39	45	52	60	72	85	97
Fork assembly length	Lfa	115	138	172	200	239	272	303	326	388	433	511	624	709
Spade assembly length	Lsa	115	138	172	200	239	272	303	326	388	458	536	649	734
Thickness	W2	24	28	35	42	52	64	74	84	95	120	148	170	181
Jaw gap (fork only) +0/-2mm	T2	14	16	19	24	30	36	39	44	49	59	76	86	91
Spade thickness	T1	10	12	15	20	25	30	35	40	45	55	70	80	85
Width	D1	32	43	51	62	79	93	107	121	145	167	199	246	287
Overall pin length	Lp	34.5	38	48	55	73	85	99	110	120	149	183	213	223

All dimensions in mm. For full design details see pages 14 & 15

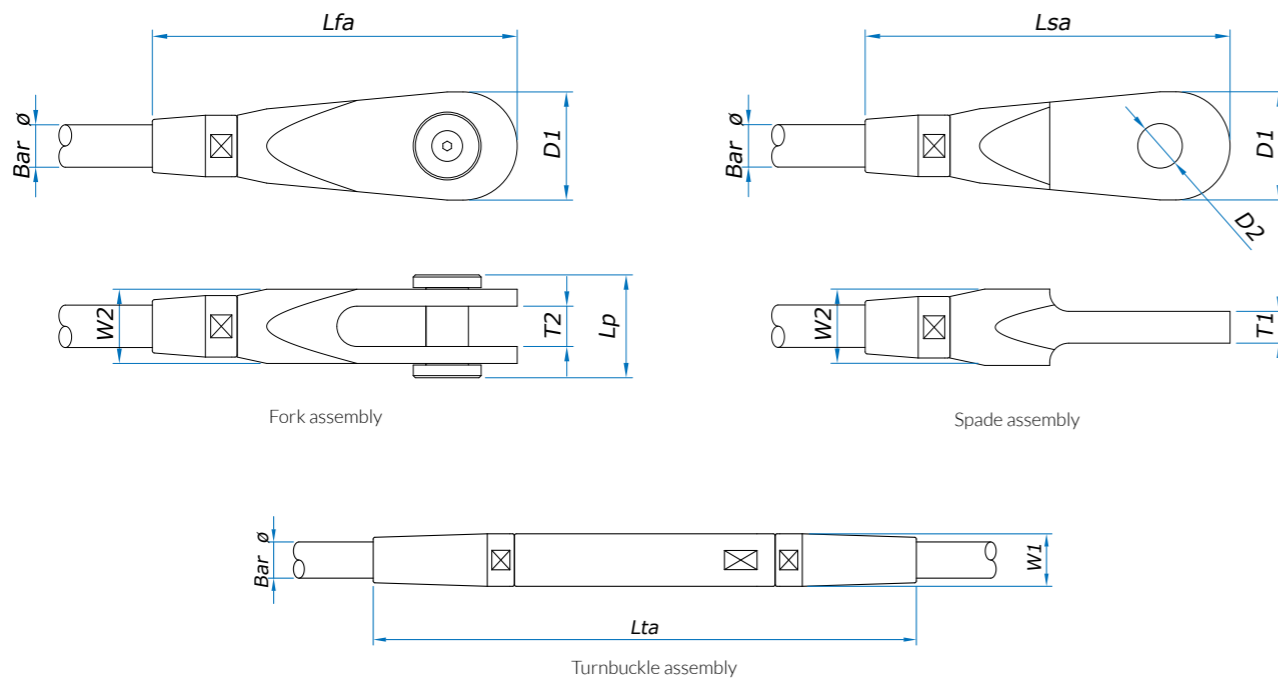

T3 Turnbuckles

		M12	M16	M20	M24	M30	M36	M42	M48	M56	M64	M76	M90	M100
Nominal bar diameter		12	16	19	22	28	34	39	45	52	60	72	85	97
Turnbuckle assembly length	Lta	130	150	300	322	344	366	398	420	442	464	504	596	635
Diameter	W1	18	24	29	35	43	52	60	68	80	91	108	129	143

Tendon Adjustment		M12	M16	M20	M24	M30	M36	M42	M48	M56	M64	M76	M90	M100
Fork - fork	+/- mm	15	15	15	20	20	20	25	25	-	-	-	-	-
Per turnbuckle	+/- mm	25	25	50	50	50	50	50	50	50	50	50	50	50

All dimensions in mm. For full design details see pages 14 & 15

T4 DST520 System Mechanical Properties

Grade 520 Carbon Steel Bar		M12	M16	M20	M24	M30	M36	M42	M48	M56	M64	M76	M90	M100
Yield load	kN	44	82	127	184	292	425	583	766	1056	1392	1999	2879	3605
Ultimate load (break load)	kN	55	102	159	229	364	531	729	958	1320	1739	2528	3634	4547
Nominal bar diameter	mm	12	16	19	22	28	34	39	45	52	60	72	85	97
Stress area	mm ²	84	157	245	353	561	817	1121	1473	2030	2676	3889	5591	6995
Yield stress	N/mm ²	520	520	520	520	520	520	520	520	520	520	520	520	520
Ultimate stress	N/mm ²	650	650	650	650	650	650	650	650	650	650	650	650	650
Elongation	%	12	19	19	19	19	19	19	19	19	19	19	19	19
Maximum single bar length	m	6	12	12	12	12	12	12	12	12	12	12	12	12
Bar specification	Grade 520 bars, fine grained micro alloyed steel with enhanced mechanical properties. All carbon steel bar is fully weldable.													
Thread specification	Rolled metric threads to BS3643													
Length tolerance	+/- 3mm for M12 to M100													



Grade 520 Stainless Steel Bar		M12	M16	M20	M24	M30	M36	M42	M48	M56
Yield load	kN	44	82	127	184	292	425	583	766	1056
Ultimate load (break load)	kN	55	104	162	233	370	539	740	958	1320
Nominal bar diameter	mm	12	16	19	22	28	34	39	45	52
Stress area	mm ²	84	157	245	353	561	817	1121	1473	2030
Yield stress	N/mm ²	520	520	520	520	520	520	520	520	520
Ultimate stress	N/mm ²	660	660	660	660	660	660	660	660	660
Maximum single bar length	m	6+	6+	6+	6+	6+	6	6	6	6
Bar specification	Grade 316 stainless steel, cold drawn bar to BS970 or Duplex stainless steel									
Thread specification	Rolled metric threads to BS3643									
Length tolerance	+/- 3mm for M12 to M56									



Download More

Additional data, 2D & 3D models are available to download from:
www.daverbarandcable.co.uk/information-resources/download

Product Data

T5 Fork and Spade Dimensions

		M12	M16	M20	M24	M30	M36	M42	M48	M56	M64	M76	M90	M100
Fork length	Lf	90	112	132	155	189	217	243	266	313	348	420	498	575
Spade length	Ls	90	112	132	155	189	217	243	266	313	373	445	523	600
Diameter	W1	18	22	29	35	43	52	60	68	80	91	108	129	143
Thickness	W2	24	28	35	42	52	64	74	84	95	120	148	170	181
Jaw gap (fork only) +0/-2mm	T2	14	16	19	24	30	36	39	44	49	59	76	86	91
Spade thickness	T1	10	12	15	20	25	30	35	40	45	55	70	80	85
Width	D1	32	43	51	62	79	93	107	121	145	167	199	246	287
Pin hole diameter	D2	13	17	21	25	31	37	43	50	58	66	78	96	111
Projection	L1	21	27	33	41	52	61	69	78	96	110	131	161	188
Jaw depth (fork only)	L2	25	30	42	50	59	68	70	87	105	120	141	171	198

All dimensions in mm.

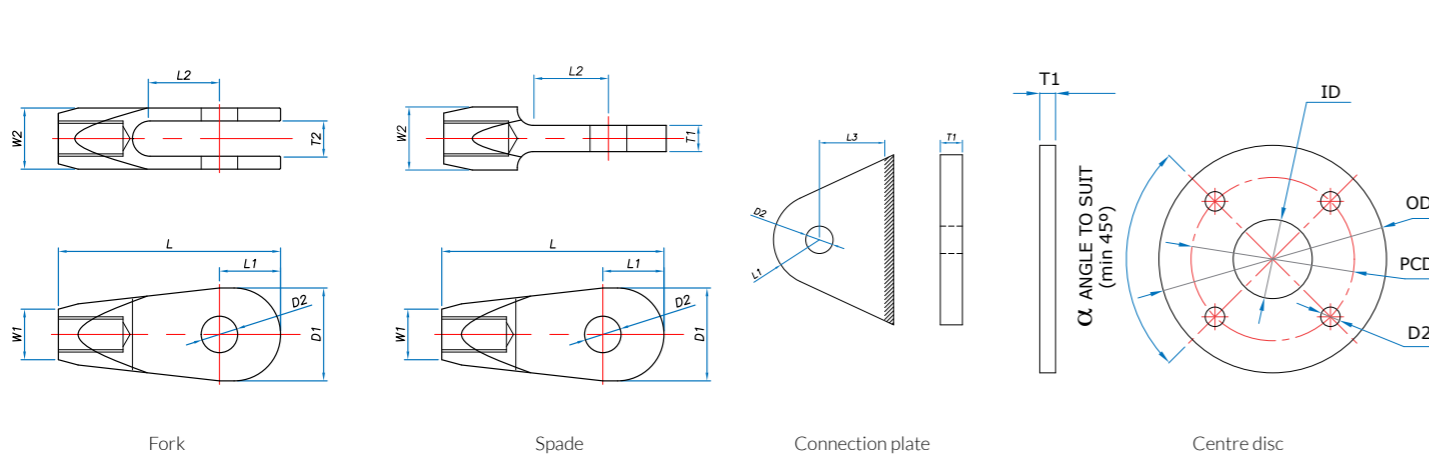

T6 Accessories

Connection Plates		M12	M16	M20	M24	M30	M36	M42	M48	M56	M64	M76	M90	M100
Thickness	T1	10	12	15	20	25	30	35	40	45	55	70	80	85
Pin hole diameter	D2	13	17	21	25	31	37	43	50	58	66	78	96	111
Projection	L1	21	27	33	41	52	61	69	78	96	110	131	161	188
Clearance	L3	32	38	52	62	74	87	97	107	125	140	161	196	222
Grade plate to BS EN 10025		S 355	S355	S355	S355	S355	S355	S355	S355	S355	S355	S355	S355	S355

Ensure clearance for paint/galvanising

Centre Discs		M12	M16	M20	M24	M30	M36	M42	M48	M56
Thickness	T1	10	12	15	20	25	30	35	40	45
Overall diameter	OD	145	185	245	285	350	420	490	560	660
Centre hole	ID	50	60	70	90	100	120	140	160	200
Pin hole diameter	D2	13	17	21	25	31	37	43	49	57
PCD	PCD	110	140	180	210	260	310	360	410	480
Grade plate to BS EN 10025		S355	S355	S355	S355	S355	S355	S355	S355	S355

All dimensions in mm. Ensure clearance for paint/galvanising.

For stainless steel connection plates or centre discs, marine grade stainless with a minimum tensile strength of S355 must be used.

T7 Accessories

Pinsets		M12	M16	M20	M24	M30	M36	M42	M48	M56	M64	M76	M90	M100
Pin diameter	D3	12	16	20	24	30	36	42	48	56	64	76	94	109
Pin body length	W2	24	28	36	43	53	65	75	86	96	121	153	173	183
End cap diameter	D4	20	25	32	35	50	55	60	60	70	86	100	120	140
End cap thickness	C	3	5	6	6	10	10	12	12	12	14	15	20	20

Lockcovers		M12	M16	M20	M24	M30	M36	M42	M48	M56	M64	M76	M90	M100
Lockcover diameter	W1	18	24	29	35	43	52	60	68	80	91	108	129	143
Fork lockcover length	L5	25	26	40	45	50	55	60	60	75	85	91	126	134
Turnbuckle lockcover length	L6	30	33	78	84	87	93	102	105	106	112	118	153	160

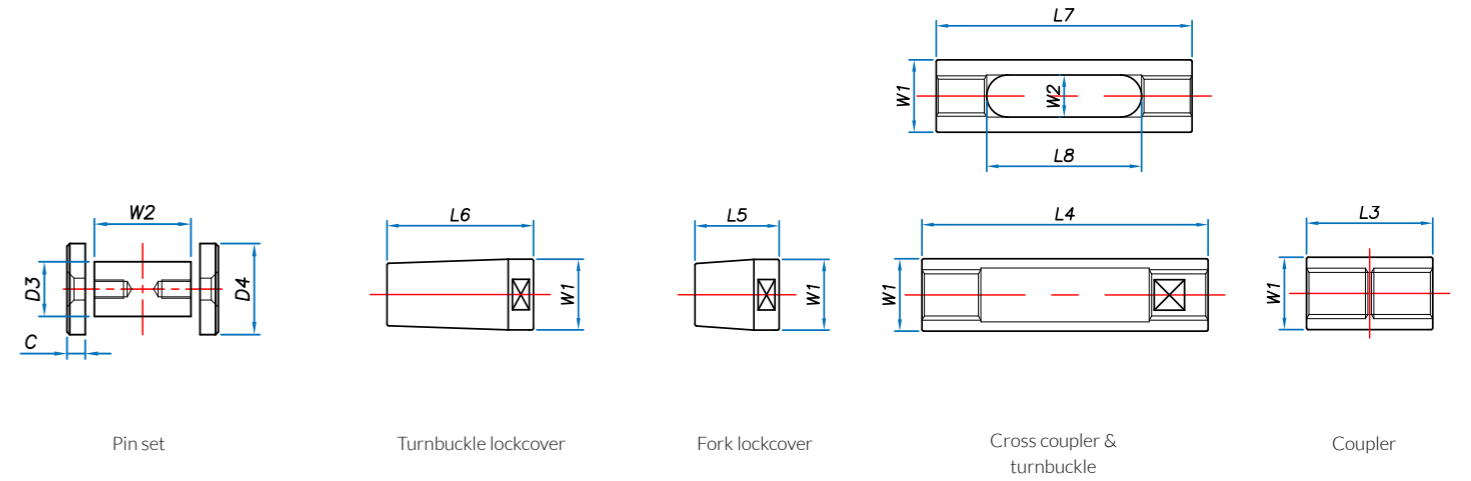

Turnbuckles/Couplers		M12	M16	M20	M24	M30	M36	M42	M48	M56	M64	M76	M90	M100
Coupler length	L3	37	45	53	64	75	89	100	115	135	145	165	195	215
Coupler/Turnbuckle diameter	W1	18	24	29	35	43	52	60	68	80	91	108	129	143
Turnbuckle length	L4	70	85	144	155	170	180	195	210	230	240	268	290	315

All dimensions in mm.

Cross Coupler (alpha min 40°)		M12	M16	M20	M24	M30	M36	M42	M48	M56
Length	L7	85	105	130	152	180	215	247	286	334
Diameter	W1	25	29	36	43	53	63	75	85	99
Slot Width	W2	14	18	22	26	32	38	44	50	58
Long Length	L8	52	65	80	92	112	135	157	180	210
Lockcover Length	L6	35	41	51	61	75	89	106	120	140
Lockcover Diameter	W1	25	29	36	43	53	63	75	85	99

All dimensions in mm.



Download More

Additional data, 2D & 3D models are available to download from:
www.daverbarandcable.co.uk/information-resources/download

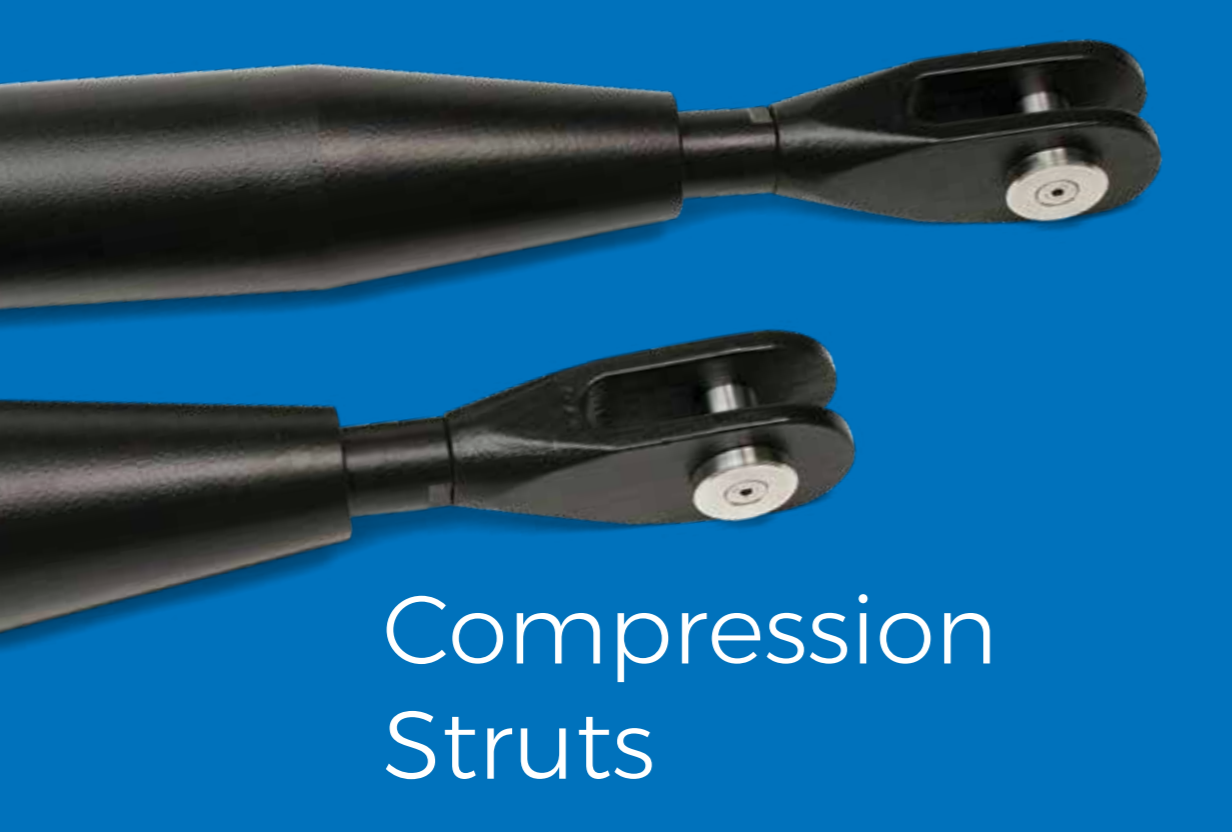

Compression Struts



Daвер Steels' compression struts at Terminal 2 Heathrow, London

To complement our existing tensile bar systems, Daвер Steels have introduced a range of adjustable compression struts to EXC 3.

A compression strut comprises a central tubular section with a welded taper connection at each end.

The taper connection forms the shape of the compression strut and is threaded to take an end connection allowing an adjustable strut for applications experiencing compressive and tensile loads.

Assembly

All compression struts are supplied fully assembled and set to the nominal pin-pin length. The installed strut can be adjusted to length by +/- 50 mm. Forks must be assembled in the same plane within 0.5° alignment.

Alternative Arrangements

Alternative end details can be designed and manufactured to suit bespoke projects, without compromising the load characteristics.

Our standard configuration uses our standard forks, a thread cover for locking and aesthetic looks, and our design of tapered cone.

The strut system is designed in accordance with EN1993-1-1 and EN1993-1-8 and their respective UK National Annexes. The ultimate capacities quoted take account of self-weight bending of the strut in accordance with equation 6.10, Table NAA1.2(B) UK National Annex to EN1990.

Our calculation methods have been validated by consultant structural design engineers.

Fittings

For all of our data on forks, lockcovers and connection plates please view T5, T6 and T7 on pages 15 and 16.

Surface Finishes

Compression struts are available in our standard surface finishes for both carbon and stainless steels.

Please see page 4 & 5 for more details.

Critical Sections

- 1 CHS verification
 - Section capacity (combined bending & axial)
- 2 Interface between CHS & welded cone
 - Weld size required
- 3 Threaded bar
 - Combined bending & axial
 - Axial resistance of thread
- 4 Fork
 - Combined bending & axial
- 5 Pin
 - Combined bending & shear

NB: Reference to 'bending' above means the summation of strut buckling and self-weight bending effects.

Partial Factors

The allowable loads refer to the minimum design resistance in kN, calculated using the UK National Annex, material and Load Factors.

Partial factors for design of building members / sections EN1993-1-1

γ_{M0}	γ_{M1}	γ_{M2}	γ_{M3}	γ_{M4}	γ_{M5}	γ_{M6}	γ_{M7}
1.00	1.00	1.10	1.25	1.10	1.00	1.00	1.00

Partial factors for design of building connections / joints EN1993-1-8

γ_{M0}	γ_{M1}	γ_{M2}	γ_{M3}	γ_{M4}	γ_{M5}	γ_{M6}	$\gamma_{M6,ser}$	γ_{M7}
1.00	1.00	1.25	1.25	1.10	1.00	1.00	1.00	1.10

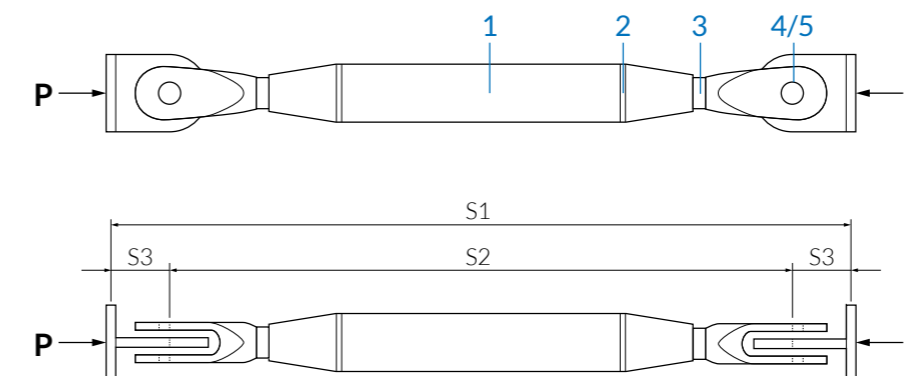

S1 = Effective length
 S2 = Pin to pin length
 S3 = Pin to point of resistance
 P = Load in kN

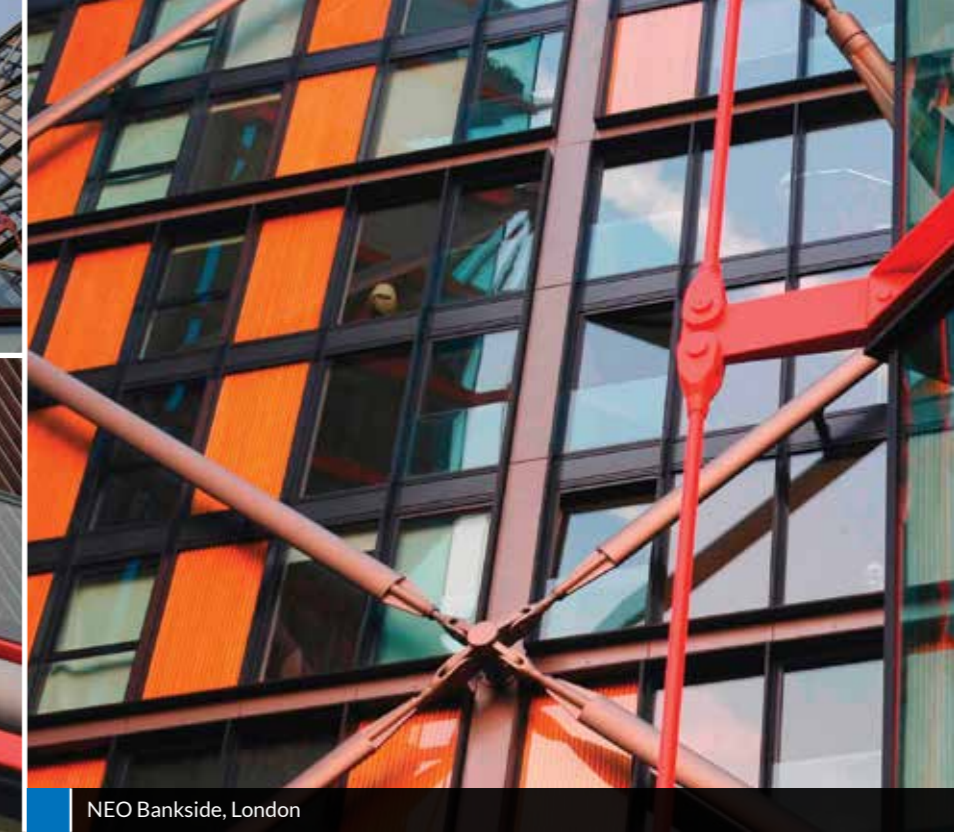

Load Capacity Data

Carbon Steel

Each compression strut is custom made, so alternative designs and end connections can be accommodated. Below are examples of typical loads which can be expected at the tabulated lengths.

T8 Carbon steel tubes: BS EN10210-1 Grade S355JR

Fork/Bar Sizes	M12	M16	M20	M24	M30	M36	M42	M48	M56	M64	M76	M90	M100
CHS Size (diameter x t mm)	33.7 x 4	42.4 x 4	48.3 x 5	60.3 x 5	76.1 x 5	88.9 x 5	114.3 x 6.3	139.7 x 10	168.3 x 10	193.7 x 10	244.5 x 16	273 x 16	323.9 x 16
S1 m	P -- Design Resistance in kN												
1.5	8	25	45	74	127	216	306	426	600	837	1207	1807	2376
2		17	29	56	127	216	306	426	600	837	1207	1807	2376
2.5		13	22	40	98	202	306	426	600	837	1207	1807	2376
3		10	18	31	74	153	306	426	600	837	1207	1807	2376
3.5			15	26	60	122	306	426	600	837	1207	1807	2376
4			13	22	51	102	199	359	600	837	1207	1807	2376
4.5			12	20	44	88	168	300	560	837	1207	1807	2376
5			10	17	39	78	146	258	480	781	1207	1807	2376
5.5				16	35	66	129	226	416	683	1207	1807	2376
6				14	32	55	116	201	367	600	1194	1807	2376
6.5				13	29	47	106	182	328	532	1074	1783	2376
7				11	24	40	97	166	297	478	965	1624	2376
7.5				10	21	35	90	154	272	434	872	1475	2376
8					18	30	82	143	251	398	793	1342	2226
8.5					16	27	72	133	233	368	727	1226	2062
9					14	23	64	125	218	342	670	1126	1908
9.5					12	21	57	118	205	320	623	1041	1767
10					11	18	51	112	194	301	582	968	1640
11					9	15	41	101	175	270	515	849	1429
12						12	34	93	159	245	464	759	1265
S3 mm max	50	50	50	75	100	100	100	125	125	175	200	225	250

Tubes with a higher minimum yield can be acquired on a longer lead time for specific projects. We can provide our calculations to ensure your design meets the building requirements.

Stainless Steel

T9 Stainless steel tubes in grade 316 to BS EN10296 - min. Yield Stress of 230 N/mm²

Fork/Bar Sizes	M12	M16	M20	M24	M30	M36	M42	M48	M56
CHS Size (diameter x t mm)	33.7 x 4	42.4 x 4	48.3 x 5	60.3 x 5	76.1 x 5	88.9 x 5	114.3 x 6.3	139.7 x 10	168.3 x 10
S1 m	P -- Design Resistance in kN								
1.5	6	18	39	78	159	270	382	426	772
2		12	26	48	123	261	382	426	772
2.5		10	19	35	84	178	382	426	772
3			16	27	65	133	287	400	772
3.5			13	23	53	107	222	388	600
4			12	20	45	90	181	327	636
4.5			10	17	39	78	154	275	523
5				16	35	67	134	237	441
5.5				14	32	55	119	208	381
6				12	27	45	108	187	336
S3 mm max	50	50	50	75	100	100	100	125	125

Tubes with a higher minimum yield can be acquired on a longer lead time for specific projects. We can provide our calculations to ensure your design meets the building requirements.



High Strength Threaded Bars DSHT Bar



High strength threaded bar in wind turbine construction

Applications

High strength bar is used widely throughout the Civil & Structural Engineering industry. Typical uses include:

- Holding down bolts
- Temporary works
- Tie bars
- Masonry tensioning

Daver Steels HT Bar

Daver Steels offer high strength threaded bar equivalent to Grade 10.9 and conforming to the requirements of BS EN ISO 898-1. DSHT bar has a high yield stress (typically 900N/mm²) but unlike some other HT bars also has a good V-notch toughness (min 45J @ 20°C and 27J @ -20°C).

Standard diameters available are M30 to M56 and lengths of 6m. Larger diameters and lengths are available at special request but may be subject to increased lead time.

Threads are standard metric coarse pitch to BS 3643 class 8g and allow a variety of standard and special fittings to be used. Left hand threads can also be supplied, by request.

Alloy Steels & Stainless Materials

Carbon bars are made from a heat treated alloy and threads are rolled to provide greater fatigue resistance. All material is independently tested for mechanical properties. An equivalent stainless steel high strength threaded bar is also available.

Stressing

Daver Steels can offer stressing equipment for hire or sales and advise on site stressing procedures. Our standard metric threads make stressing easier and the equipment readily available

Fittings Available

- Hex nuts
- End plates
- Couplers
- Washers

Please contact our sales department for more information

Finishes (Corrosion Protection)

- Grease
- Greenkote™
- Denso Tape
- Zinga
- Paint
- Heat shrink tube

Site Precautions

DSHT bar is a heat treated steel and must not be welded or be subjected to heat (e.g. welding / cutting / grinding / sparks).

DSHT bar can easily be cut on site using discs or blades but heat must be kept to a minimum (flame cutting must not be used).

Manufacture

ISO 9001, 3.1 Certification, CE marked. Third party tensile tests available. European made and sourced.

T12 Hydraulic Jacks

The table below gives the main dimensions of hydraulic jacks available from Daver Steels.

Bar Dia mm	Weight kg	Type	Max load kN	Min Bar Centres	B mm	D mm	L1 mm	L2 mm	L3 mm
30	3.5	DJ2	457	80	102	90	60	128	236
36	6.5	DJ3	822	100	133	117	75	155	277
42	11	DJ4	1264	110	163	155	85	165	305
48	11	DJ4	1264	115	163	155	100	165	342
56	16	DJ5	1833	135	193	181	110	187	342

T13 Mechanical Properties

	Code	DSHT30	DSHT36	DSHT42	DSHT48	DSHT56
Bars	Thread Diameter	30	36	42	48	56
	0.2% Proof (yield) load (min)	kN 505	735	1009	1326	1827
	Failure (break) load (min)	kN 617	899	1233	1620	2233
	Design load according EC3	kN 480	699	959	1167	1608
	0.2% Proof stress (min)	N/mm ² 900	900	900	900	900
	Ultimate stress (min)	N/mm ² 1100	1100	1100	1100	1100
	Thread stress area	mm ² 561	817	1121	1473	2030
	Thread pitch	mm 3.5	4	4.5	5	5.5
	Standard end thread length	mm 200	250	250	250	300
	Nominal bar diameter	mm 28	34	39	45	52
	Mass per metre	kg 4.8	6.8	9.3	12.2	16.8
	Max length without coupling	m 12	12	12	12	12
Hex Nuts	Width across flats	mm 46	55	65	75	85
	Width across corners	mm 53.1	63.5	75.1	85.6	98.1
	Length	mm 24	29	34	38	46
Flat Washers	Outside diameter	mm 90	108	126	144	168
	Thickness	mm 8	10	12	12	15
Couplers	Outside diameter	mm 48	53	63	73	83
	Length	mm 75	89	100	115	135

Min Elongation (A5) : 10%

Min Charpy (V Notch) : 45J @ 20°C, 27J @ -20°C.

Typical Brinell Hardness : 300 - 350 HBW

