

DYNA Force[®] Elasto-Magnetic Force Monitoring System





We do not only talk about service – we offer it!

As a service provider, DYWIDAG-Systems International offers professional support by experts and the training of installation Personnel on site.

Our goal is to fulfill your expectations day by day.

Contents

Introduction	4
Fields of Application	4
Key Features.....	4
System Description	5
System Components.....	6
Technical Data	7
Installation Process	9
Anchor with DYNA Force® Sensor	9
Stressing.....	9
Stationary Measurement System.....	9
Anchor with Sensor Cable	9
Installed Anchors	9
Installed and Connected Anchor.....	9
Software.....	9
DYNA Force® Sensors installed on Geotechnical Systems.....	10
DYNA Force® Sensors installed on Post-Tensioning Systems	11
References – Dam Applications.....	12
References – Geotechnical Applications.....	13
References – Bridge Applications	14
References – Other Applications	16



Introduction

There is an increasing demand for health monitoring systems for geotechnical applications as well as for bridges and buildings. For these structures, steel elements that are either prestressed or subject to high compression forces are key elements for achieving the scheduled performance of the structure. On many occasions during the construction and service life of a structure, it is of decisive importance to know the stress level / the axial forces of the steel elements in use. Although there are many methods to measure the axial force, most of them are cumbersome, expensive, and the accuracy varies depending on the method used. DYWIDAG-Systems International actively participated in the development, testing and utilization of the DYNA Force® System for measuring the force in steel bars or strands.

The force measuring technique is based on the elasto-magnetic properties of ferromagnetic materials and is carried out using DYNA Force® Sensors. The magnetic permeability of steel in a magnetic field changes as a function of the mechanic normal stress condition of the steel. By measuring the relative change in magnetic permeability, the normal stress in the steel tendon can be determined. The DYNA Force® Monitoring System is based on the principle described above and can be used for bars, strands and wires.

The hollow cylinder monitoring sensors are available in different diameters to suit various bar and strand diameters.

A readout unit measures the magnetic permeability of the steel tendon through the sensor and shows the tendon force. Each DYNA Force® Sensor is fitted with an integrated temperature sensor in order to automatically compensate the influence of possible temperature alterations.

The DYNA Force® System allows the permanent monitoring of post-tensioning forces in steel tendons.

Force readings as part of inspection procedures can be done within a few minutes without the need for lift-off equipment or other cost-intensive techniques.

Fields of Application

- Ground Anchors
- Tie-back and Tie-down Anchors
- Micropiles
- Soil Nails
- Cable Stayed Bridges
- Post-Tensioning Tendons in Bridges and Buildings
- Air Traffic Control Towers
- Wind Energy Towers
- Repair and Strengthening of Post-Tensioned Structures

Key Features

- Lifetime monitoring of the post-tensioning performance in structures
- Knowledge that their post-tensioning design is working as intended. The system permits posterior analysis and potential adjustment at any time in the future
- Monitoring of tendon forces at any time with alert warning
- Quality and support from the leading industry supplier
- Sensors can either be mounted in the factory or on site
- Typically, no extra work or interference with post-tensioning installations
- No large load cell at anchorages and no increased pocket depth
- Load check during stressing
- Increased construction site safety
- The electronic force readout is safe and reliable
- Easy connection with mobile devices by WiFi
- Can be controlled on-site (WiFi) or remotely (SimCard)



DYNA Force® Sensor

System Description

Manual System for Single Anchors

Key Features

- Each DYNA Force® Sensor is individually connected to the readout unit either directly, or optionally via a multiplexer
- Force and temperature readings are realized sensor by sensor via the readout unit
- Local digital data storage
- Download and control option between readout unit and mobile devices via WiFi

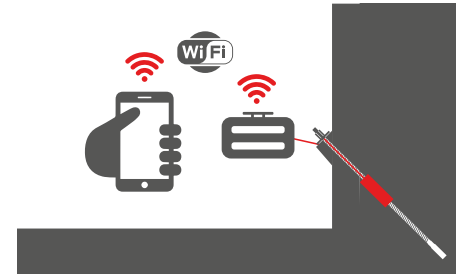

Multiple Reading System – Local Network

Key Features

- Automatic readings of all connected sensors
- Reading interval can be defined by the customer
- Local digital data storage
- Download and control option from a remotely located laptop via WiFi or network connection
- Data can be imported to various programs for analysis

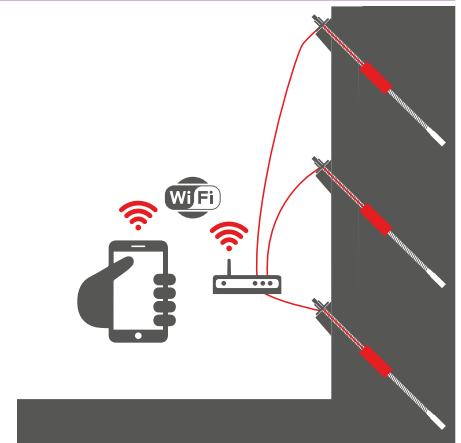

Fully Automatic Reading System – GSM (SimCard) / WiFi

Key Features

- All DYNA Force® Sensors are bundled and connected to the readout unit by multiplexers
- Multiple readings of all sensors can be done from a central location with a single click or automatically
- Local digital data storage
- Download and control option from a remotely located laptop via WiFi or GSM connection
- Data can be imported to various programs for analysis
- Possibility to integrate DYNA Force® with other measurement instruments (for example wind speed, pore water pressure, slope measurements,...) in standard software

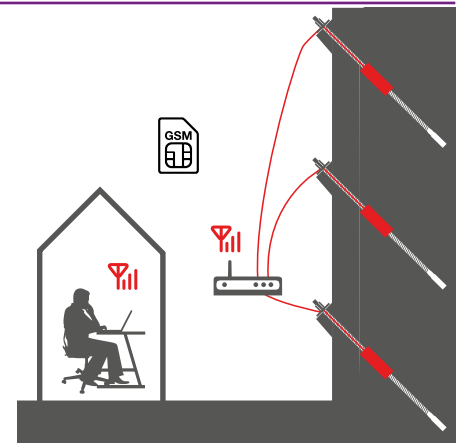

Manual System for Single Anchors with Rechargeable Battery



Installation of DYNA Force® Sensor over Strand Anchor Bond Length

System Components

Overview

Essential System Parts	Manual System for Single Anchors	Multiple Reading System	Fully Automatic Reading System
Readout unit	X	X	X
Sensors	X	X	X
Multiplexers	X	X	X
Laptop/PC/Mobile devices	X	X	X
Controller/Remote box			X
Extension cables for connecting the multiplexers with the readout unit	X ¹⁾	X	X
Main cables (for connecting the multiplexers with the readout unit)	X	X	X
AC (230V) or DC (12V/24V) power cord ³⁾	X	X	X
Wireless or ethernet cable	X	X	X
DYNA Force® Software for data processing	X	X	X
SimCard/Ethernet network (provided by customer)			X
Optional: Power supply via 12V/24V batteries, power controller and solar panel	X ²⁾	X ²⁾	X ²⁾

1) Depends on the accessibility of the sensor connectors on site

2) Just in case the usual AC or DC power supply is not available

3) Local power supply has to be provided by the customer



Technical Data

DYNA Force® Sensor

Key Features

- Sensor works touchless and non-destructively
- Every DYNA Force® Sensor includes a temperature sensor to take into account the temperature influence during force readings
- Each DYNA Force® Sensor is equipped with a unique chip for identification
- Sensors and source material (strand/bar) can either be calibrated on site or at DYWIDAG-Systems International's factory prior to shipping to the construction site
- Sensors are robust and have no moving parts. All interior connections are sealed by epoxy coating
- The maximum cable distance between readout unit and DYNA Force® Sensor is 150m
- Installation of sensors is either done during the production of the anchors or directly at the jobsite before stressing the steel tendon
- Operating temperature
 - -20[°C] up to +80[°C]

DYNA Force® Sensor Data

Type	Steel Element Diameter [mm]	Inner / Outer Sensor Diameter [mm]	Sensor Length [mm]
Single Strand	15.3 - 15.7	20 / 38	83
Bar Tendon	16 - 36	40 / 64	220
Bar Tendon	40 - 47	50 / 76	220
Bar Tendon	50 - 63.5	65 / 89	220
Bar Tendon	75	80 / 108	260
Wire EX / Strand Bundle		90 / 114	260
Wire EX / Strand Bundle		100 / 129	260
Strand Bundle		110 / 140	220
Strand Bundle		119 / 160	240

Readout Unit

- Measurement range
 - 0 - 95% yield stress level of the steel tendon
- Power supply
 - AC: 90-246[V], 60/50[Hz], 300[W]
 - DC: 12[V] / 24[V], peak 17A, standby 200[mA]
- Operating temperature
 - 0[°C] up to 50 [°C]
 - Temperatures below 0[°C] are possible using a special casing

Multiplexer

- Standard multiplexers
 - 4 channels
- Serial connection of 1 to 16 of multiplexers via main cable possible
- Additional standard enclosure in case of outside storage: painted steel or stainless steel available

Cables

- Main cable
 - 16 contacts
 - Connector body
 - Nickel plated
 - PVC jacket
- Extension cable
 - Connector body
 - Plastic
 - PVC jacket

Technical Data

System Accuracy

- Tests have confirmed the high measuring accuracy of the DYNA Force® Sensors
- The diagram on the right shows the anchor force of a 59-0.6" strand anchor subject to different load levels
- DYNA Force® Sensors correspond very closely with the jack readings during the loading stages
- Throughout the testing, the DYNA Force® Sensors were consistently more accurate than the load cells

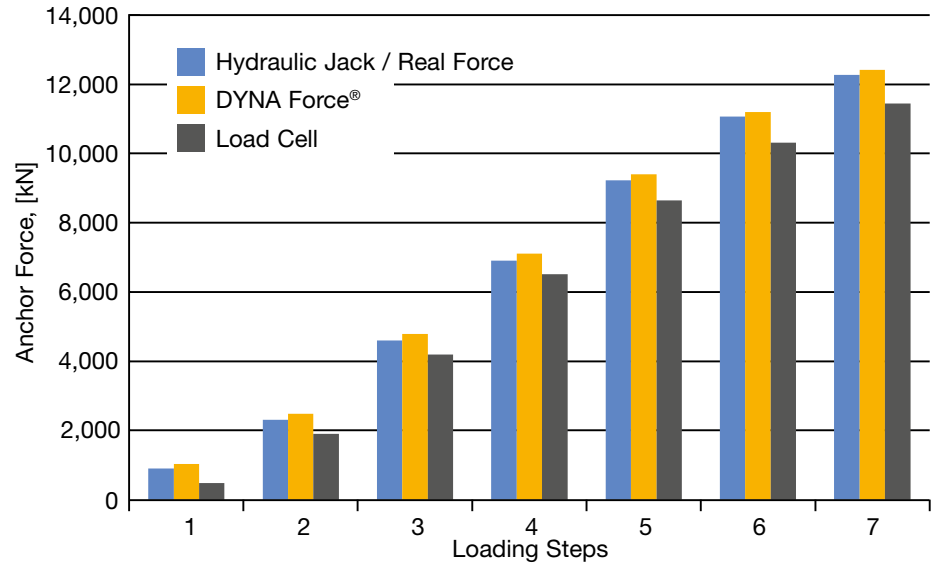

System Variants

Series Connection System

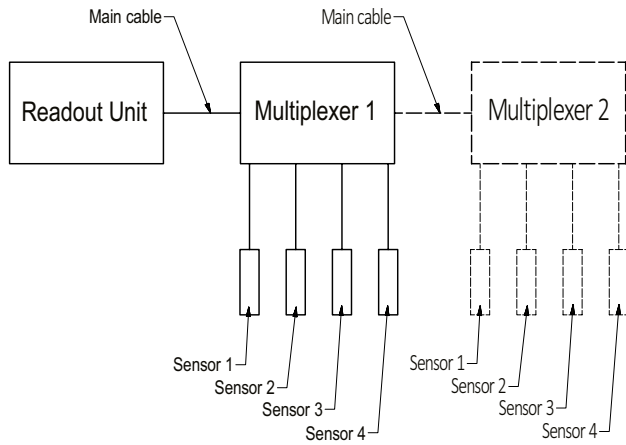

Combined Installation

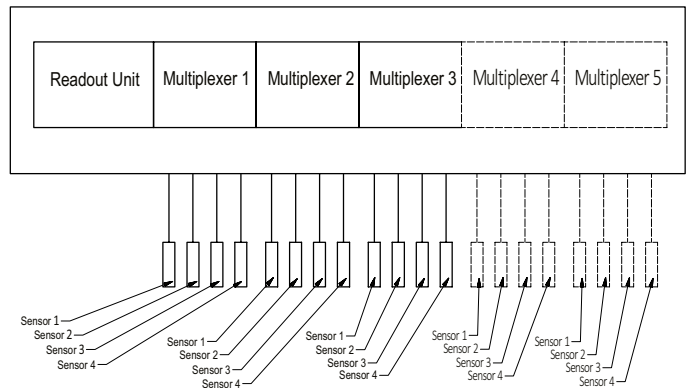

Installation Process

Anchor with DYNA Force® Sensor



Stressing



Anchor with Sensor Cable



Installed and Connected Anchor



Stationary Measurement System



Installed Anchors



Software



DYNA Force® Sensors installed on Geotechnical Systems

DYWIDAG Bar Anchors

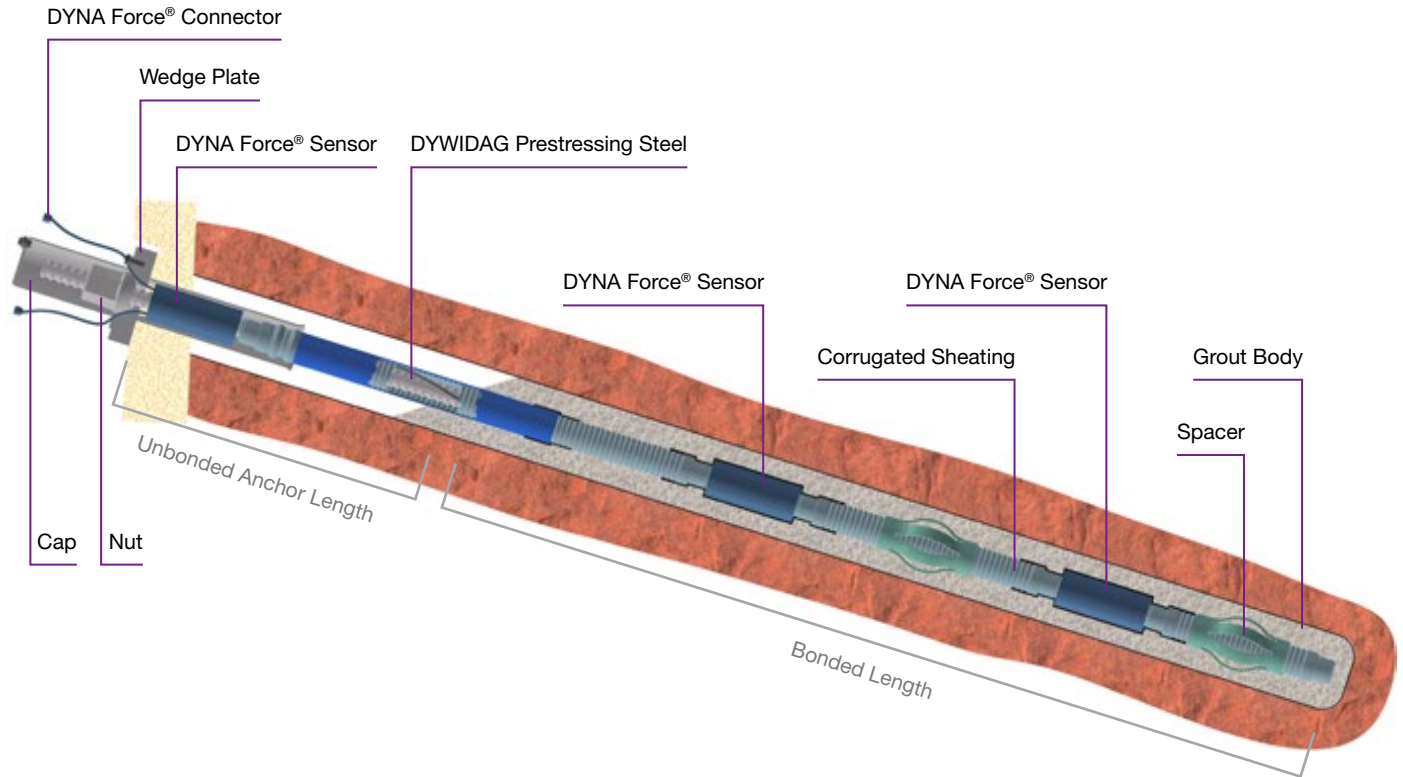

DYWIDAG Strand Anchors

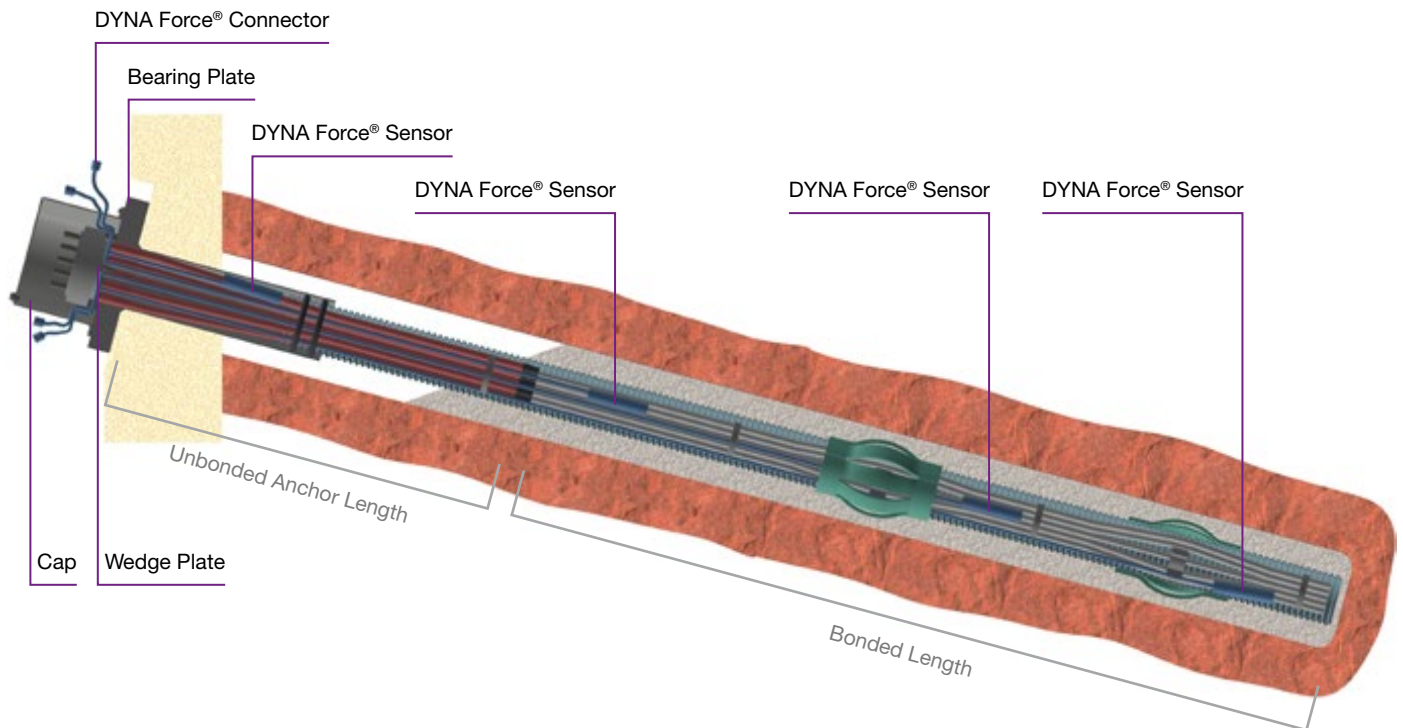

DYNA Force® Sensors installed on Post-Tensioning Systems

DYNA® Grip Stay Cable System

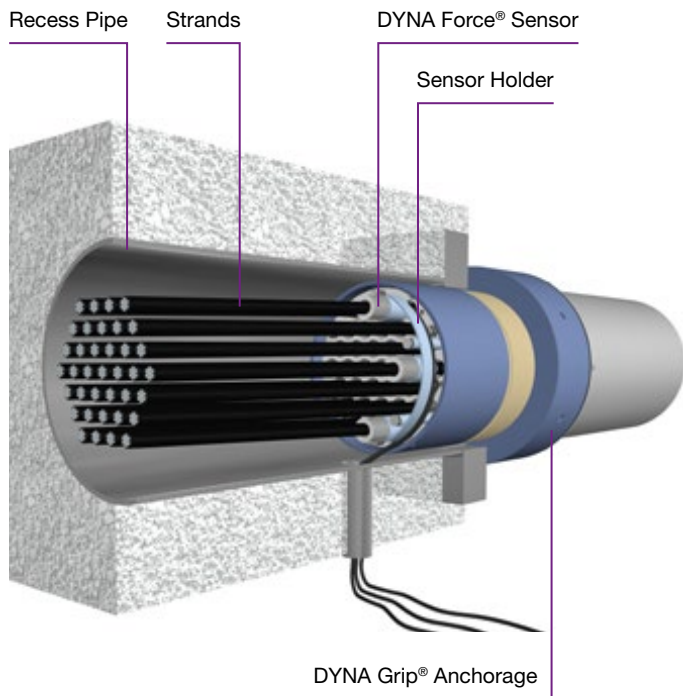

DYWIDAG MA Anchorage

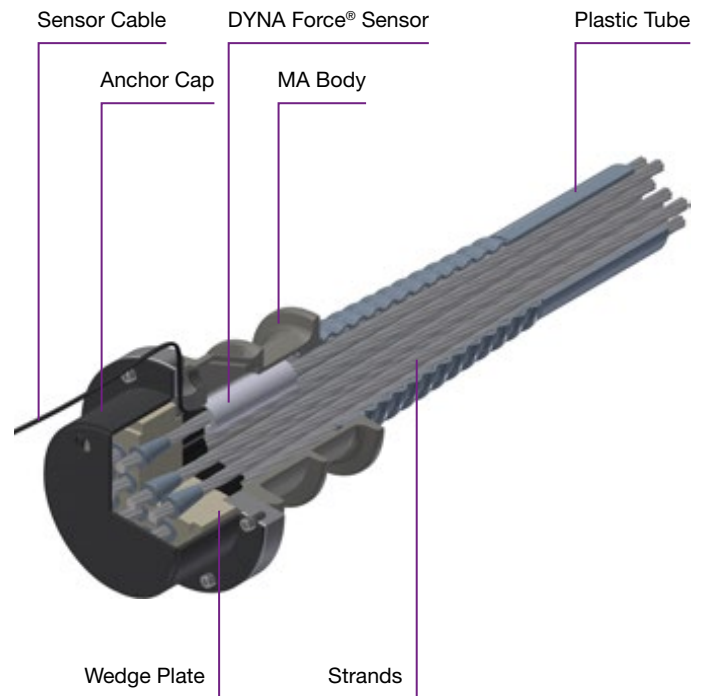

DYNA Force® Sensors installed on Wire Ex Tendons

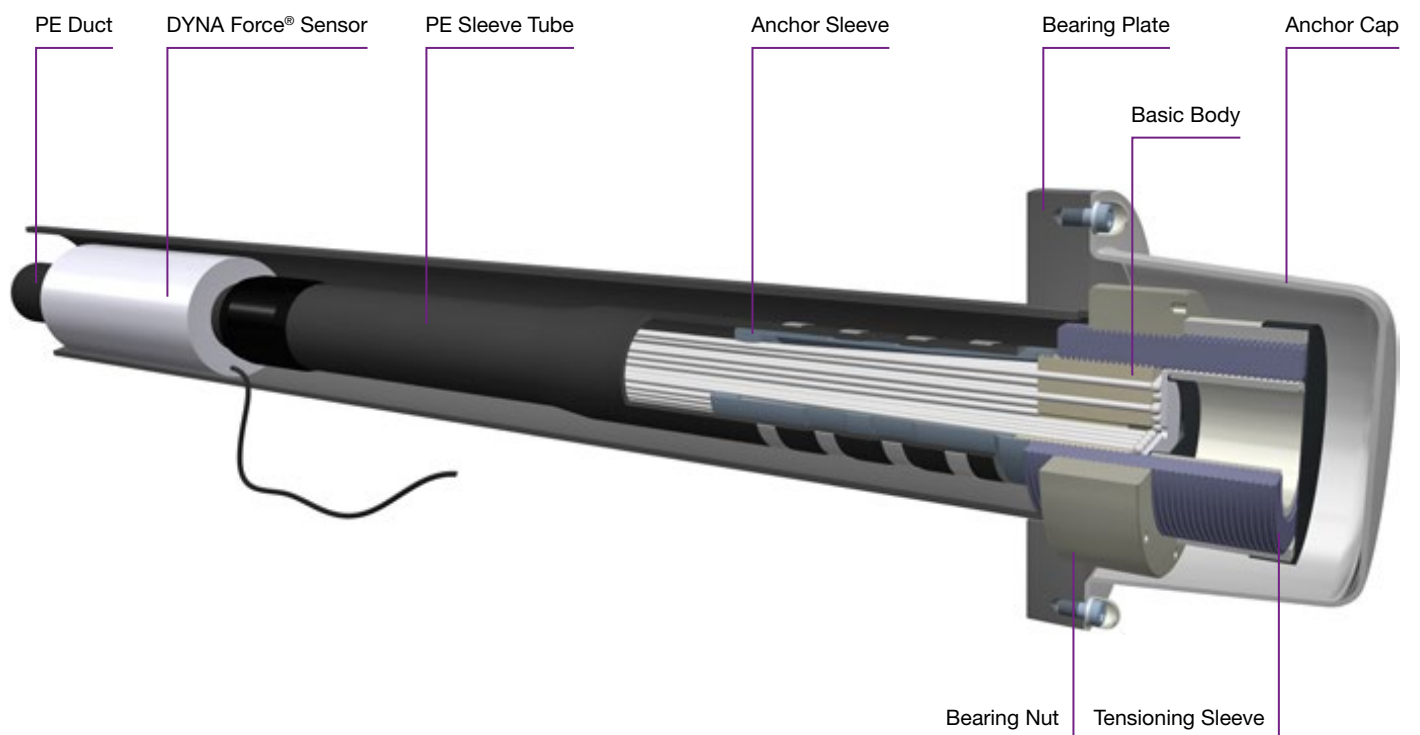

Maximum Flexibility: Restressable Anchor Heads for Choranche Dam, France



i **Owner** EdF, France +++ **General Contractor** Eiffage, France +++ **Subcontractor** Résirep, France +++ **Consulting Engineers** EdF, France
Unit DSI France SAS, France
Scope Development, production, supply, engineering services, technical support, supervision
Products 8 Type 13-0.62" DYWIDAG Strand Anchors, 8 Type 22-0.62" DYWIDAG Strand Anchors, 4 DYNA Force® Sensors, 1 Readout Unit

DYWIDAG Strand Anchors with DYNA Force® Sensors secure Grancarevo Dam, Bosnia and Herzegovina

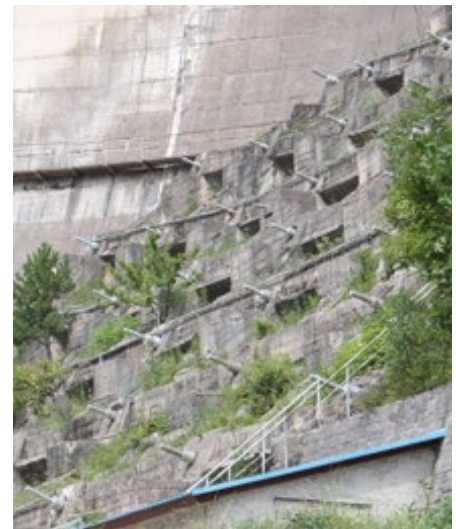

i **Operator** HET (Hidroelektrane na Trebišnjici), Bosnia and Herzegovina +++ **General Contractor** GEOSONDA ZENICA Bosnia and Herzegovina +++ **Subcontractor** HISTEH D.O.O., Slovenia +++ **Consulting Engineers** IBE Consulting Engineers Ljubljana Slovenia
Unit DYWIDAG-Systems International GmbH, Austria
Scope Production, supply, supervision
Products Permanent Type 12-0.62", up to 61.5m long DYWIDAG Strand Anchors with double corrosion protection, EI-Iso System, 46 DYNA Force® Sensors, 4 multiplexers, 1 readout unit, 1 controller

DYNA Force® System Premiere on Frankfurt's Opera Square, Germany

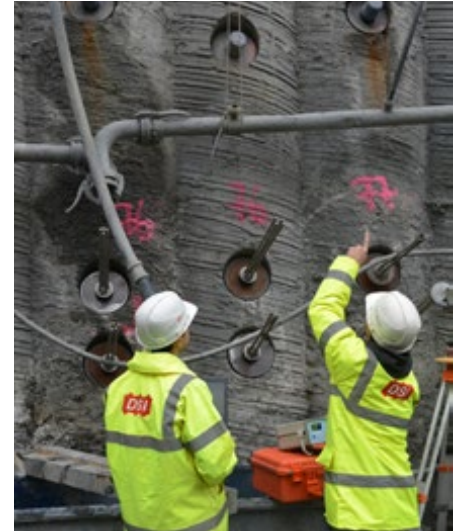

Contractor Joint venture Spezialtiefbau Opernplatz, consisting of PST Spezialtiefbau Sued GmbH and DEMLER Spezialtiefbau GmbH & Co. KG, both Germany +++ **Engineers** IGG - Ingenieurgemeinschaft Grundbau GmbH, Germany (planning of excavation)

Unit DYWIDAG-Systems International GmbH, BU Geotechnics, Germany

Scope Production, supply, installation, test installation

Products 1,700 temporary Type 4-0.6" DYWIDAG Strand Anchors, 30 DYNA Force® Sensors, Readout Unit

Sheet Pile Wall, Ile Seguin, Paris, France



Owner VNF, France +++ **General Contractor** EIFFAGE TP, France +++ **Subcontractor** SPIE FONDATIONS, France

Unit DSI France SAS, France

Scope Production, supply, technical assistance

Products 23 DYWIDAG Strand Anchors with 2 strands, 23 DYNA Force® Sensors

New Generation of Stay Cable Bridges, Penobscot Bridge, Maine, USA



Owner Maine Department of Transportation, USA +++ **General Contractor** Joint Venture consisting of Cianbro and Reed & Reed, USA
+++ **Engineer** Figg Bridge Engineers, Inc., Tallahassee, Florida, USA



Unit DYWIDAG-Systems International USA, BU Post-Tensioning, USA

Scope Development, production, supply, technical support

Products 80 DYNA Grip® Stay Cables with epoxy-coated strands, development of a pedestal support system for the installation of the cradles into the pylons, installation of HDPE ducts, delivery of 4 form travellers

DYNA Grip® Stay Cables for Gujarat's first Extradosed Bridge: The 3rd Narmada Bridge, India



Owner National Highway Authority of India, India +++ **General Contractor** Larsen & Toubro Limited, India +++ **Consulting Engineers** Precast Bridge Tech. Co., Ltd., Thailand +++ **Consulting** Joint Venture, consisting of Yogma Engineering co., Ltd., Korea and Feedback Ventures Pvt., Ltd., India



Subcontractor DSI-BRIDGECON India Pvt. Ltd., India

Scope Production, supply

Products 216 Type DG-P31, DG-P37, DG-P43 and DG-P55 DYNA Grip® Stay Cables, DYNA® Link Anchor Box System, DYNA Force® Monitoring System

Large Scale Use of DYNA Force® Sensors and DYNA Grip® Stay Cables: The Abraham Lincoln Bridge in Louisville, USA

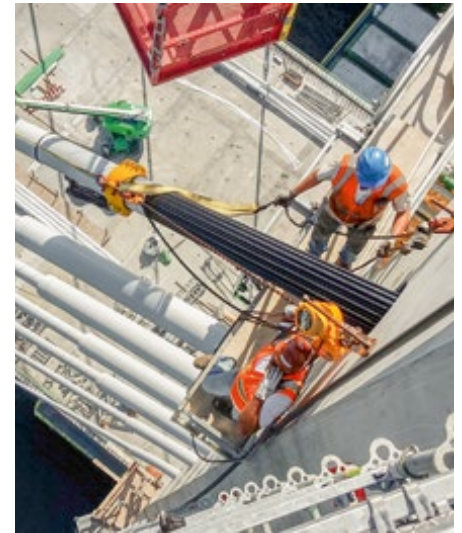

Owner Kentucky Transportation Cabinet (KYTC), USA+++ **General Contractor** Walsh Construction Company, USA +++
Contractor Milestone Contractors, L.P., USA +++ **Engineering (Lead Design)** Jacobs Engineering Group Inc., USA +++
Engineering (Design) COWI Bridge North America (formerly Buckland & Taylor Ltd.), Canada



Unit DYWIDAG-Systems International GmbH, BU Special Projects, Germany and DYWIDAG-Systems International USA Inc., BU Post-Tensioning, East, USA

Scope Production, supply, engineering services, technical support, supervision

Products 176 Type DG-P37, DG-P48, DG-P55, DG-P73, DG-P91 and DG-P109 DYNA Grip® Stay Cables, 88 internal hydraulic dampers, 264 DYNA Force® Sensors with readout unit

DYNA Force® Sensors & DYNA Grip® Stay Cable System for new Landmark: The Elbe Bridge Schoenebeck, Germany



Owner Federal State of Saxony-Anhalt and city of Magdeburg, Germany +++ **General Contractor** Landesbetrieb Bau Sachsen-Anhalt, Germany +++ **Contractor** Joint Venture, consisting of Kirchner Holding GmbH and Donges SteelTec GmbH, both Germany +++
Planner/Technical Development Leonhardt, Andrä und Partner Beratende Ingenieure VBI, GmbH, Germany



Unit DYWIDAG-Systems International GmbH, Post-Tensioning, Germany

Scope Production, supply

Products Approximately 340 t of DYWIDAG Strand Tendons and of 36 Type DG-P 31, DG-P 37 and DG-P 55 DYNA Grip® Stay Cables; DYNA Force® Monitoring System

Prefabricated Wire EX Tendons and DYNA Force® Monitoring System at Amrumbank, Germany

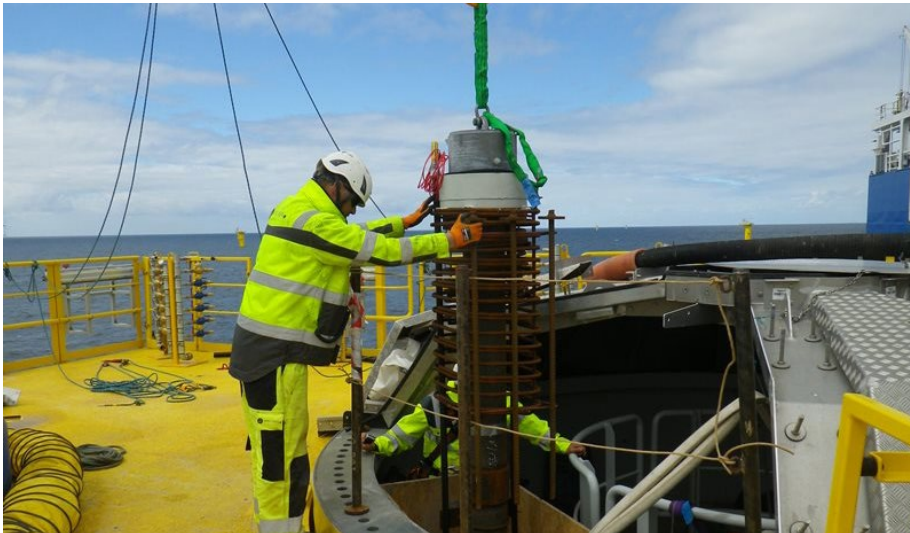

Owner Amrumbank West GmbH, Germany +++ **General Contractor** E.ON Energie Deutschland GmbH, Germany +++
Contractor Per Aarsleff A/S, Denmark +++ **Technical Consultant** Ramboll Group A/S, Denmark +++ **Engineers** grbv Ingenieure im Bauwesen GmbH & Co. KG, Germany



Unit DYWIDAG-Systems International GmbH, BU Post-Tensioning, Germany
Scope Production, supply, technical support
Products 104 Type 82 Wire EX Post-Tensioning Tendons and DYNA Force® System

Profitability through Innovation: Structural Repair of George N. Wade Memorial Bridge, USA



Owner Pennsylvania DOT, USA +++ **General Contractor** JD Eckman, Inc., USA



Unit DYWIDAG-Systems International Ltd., BU Post-Tensioning Systems, East, USA
Scope Production, supply and installation
Products 204 Double Corrosion Protected DYWIDAG-Bar Tendons, D = 46mm and DYNA Force® Sensors; design of end anchorages

DYNA Force® Sensors for new Soccer Stadium in Lille, France



Owner Communauté Urbaine de Lille Métropole, France +++ **General Contractor** Elisa (Eiffage Lille Stadium Aréna), France +++ **Engineer** Greisch, Belgium +++ **Subcontractor** Eiffel, France +++ **Consulting** Socotec, France



Unit DSI USA, BU Post-Tensioning, USA
Scope Production, supply, technical support
Products 38 DYNA Force® Sensors

DYWIDAG-Systems International supplies DYWIDAG Tendons for USA's largest Wind Technology Testing Center, USA



Owner Massachusetts Port Authority and Massachusetts Clean Energy Technology Center, both USA +++ **General Contractor** Turner Construction Company, USA +++ **Architect** Architerra Inc., USA +++ **Consulting Engineers** LeMessurier Consultants, Inc., USA



Unit DYWIDAG-Systems International USA Inc., BU Post-Tensioning, East, USA
Scope Production, supply
Products Supply of 208 19-0.6" DYWIDAG Strand Post-Tensioning Tendons, 110t Ø 46mm DYWIDAG Bar Tendons and 25 DYNA Force® Sensors; rental of equipment

DYNA Force® Sensors monitor Deep Excavations at the new Hinkley Point Nuclear Power Station, Great Britain

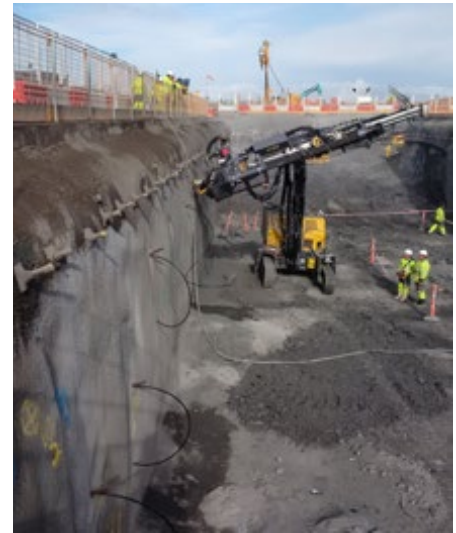

Owner Nuclear New Build Generation Company Ltd., Great Britain +++ **General Contractor** ByLor Joint Venture, consisting of BOUYGUES Travaux Publics, France and Laing O'Rourke, Great Britain +++ **Earthworks Contractor** Kier BAM Joint Venture, consisting of Kier Group plc. and BAM +++ **Engineering** AECOM, Great Britain

i **Unit** DYWIDAG-Systems International Ltd., Great Britain
Scope Production, supply, technical support, test installation
Products DYNA Force® Sensors, 14.000 25-40mm Ø GEWI® Soil Nails, double corrosion protected 40mm Ø DYWIDAG Bar Anchors

DYWIDAG Systems for the Conversion of Augsburg Main Station, Germany



i **Owner** Stadtwerke Augsburg Verkehrs-GmbH, Germany +++ **Contractor** Max Bögl GmbH & Co. KG, Germany
Unit DYWIDAG-Systems International GmbH, BU Geotechnics, Germany
Scope Production, supply, technical support
Products 170 temporary DYWIDAG Strand Anchors, 200m of 20mm Ø DYWIDAG Soil Nails and DYNA Force® System



Germany
DYWIDAG-Systems International GmbH
Neuhofweg 5
85716 Unterschleissheim, Germany
Phone +49-89-30 90 50-100
E-mail dsihv@dywidag-systems.com

Please Note:

This brochure serves basic information purposes only. Technical data and information provided herein shall be considered non-binding and may be subject to change without notice. We do not assume any liability for losses or damages attributed to the use of this technical data and any improper use of our products. Should you require further information on particular products, please do not hesitate to contact us.

www.dywidag-systems.com