

GEWI® Threadbar System

High Yield Steel for Reinforcement of Concrete





Contents

GEWI® Threadbar System	4
Technical Data for the GEWI® Threadbar.....	4
Couplers for GEWI® Threadbars.....	5
Anchorage for GEWI® Threadbars	5
GEWI® Threadbar Accessories	6
Corrosion Protection	6
GEWI® Threadbar – Connecting Reinforcement.....	7
GEWI® Threadbar – Prefabricated Connecting Reinforcement	8
GEWI® Threadbar – Prefabricated Connecting Reinforcement	9
GEWI® Threadbar – Typical Applications for Reinforcing Concrete.....	10
GEWI® Threadbar – Further Applications	10
GEWI® Threadbar – Mounting Connecting Reinforcement.....	11
GEWI® Threadbar – Assembly Instructions for Couplers.....	11



GEWI® Threadbar System

Key features of the system are:

- Fully threaded bar – can be cut and coupled at any point.
- Robust threadform – ideal for construction site use.
- Coarse pitch threadform with two flats – ensures self-cleaning of thread.
- Fully galvanized systems – galvanized threadbars and accessories also available from stock.

The *GEWI*® Threadbar System consists of high yield *GEWI*® screwable steel and corresponding coupling and anchoring accessories, which enable easy connections to and anchorages of *GEWI*® steel. In accordance with the German certificates of approval Z-1.5-76, Z-1.5-149 and Z-1.5-2.

GEWI® Steel High Yield Threadbar is a highly ductile which features a coarse left-hand thread over its full length. The system is proven worldwide and offers versatility in a range of applications.

Manufactured in accordance with the German Certificate of Approval issued by the Deutsches Institut für Bautechnik, the system also offers general conformance with BS 4449 : 1997 (Carbon Steel Bars for Prestressing of Concrete).

The minimum specified characteristic yield strength is 500N/mm² for bar diameters 16 - 50mm and 555N/mm² for the 63.5mm diameter bar. 16 - 50mm bars can be welded using appropriate industry practices relative to the carbon content of the steel. Welding of the higher grade 63.5mm diameter bar is not recommended.

Technical Data for the *GEWI*® Threadbar

GEWI® Bar Diameter	Steel Grade Yield f_y/Tensile Strength f_t ¹⁾	Ultimate Tensile Force F_t ^(a)	Yield Force F_y	Cross Sectional Area	Diameter over Threads	Bar Weight
[mm]	[N/mm ²]	[kN]	[kN]	[mm ²]	[mm]	[kg/m]
16	500/550	111	100	210	19	1.58
20	500/550	173	157	314	23	2.47
25	500/550	270	245	491	29	3.85
28	500/550	339	308	616	32	4.83
32	500/550	442	402	804	36	6.31
40	500/550	691	628	1,257	45	9.87
50	500/550	1,080	982	1,963	56	15.40
63.5	555/700	2,219	1,758	3,167	69	24.80

1) *GEWI*® Threadbars also meet the requirements according UK standard (500/600 N/mm²) and Austrian standard (550/620 N/mm²).

(a) For geotechnical applications, 75% of the ultimate tensile force F_t may be used for testing

Modulus of elasticity: $E = 205,000\text{N/mm}^2 \pm 5\%$.

Stock lengths: All bar diameters 12.0m. Tolerances $\pm 100\text{mm}$. Special lengths up to 15.0m can be ordered.

All bar diameters can be cut to length to suit customer requirements, or can be supplied bent.

Couplers for GEWI® Threadbars

Couplers allow GEWI® Threadbars to be coupled or extended reliably and efficiently. The choice of the type of coupler used depends on the application.

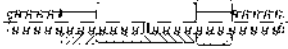

Static Coupler

The static coupler is used either in constant tension applications or in a combination of tension and compression loading. The longer dynamic couplers are to be used when vibration and cyclical load reversals are

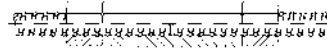

Dynamic Coupler

anticipated. Lock nuts must be used at each end of the couplers. Torqued to a predetermined value, they prevent the development of cracks in structural concrete.

Coupler strength = 1.3 x Yield Strength of the bar in accordance with German Approval Certificates. According to UK Standards, this equates to 1.08 of Ultimate Strength.

For the connection of GEWI® Threadbars with different diameters,

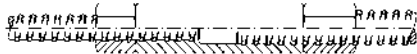

Transition Coupler

special transition couplers are available. In addition, DSI provides solutions for

connecting fixed and therefore not pivotable GEWI® bars.



Tensioning Coupler

For couplers exposed to compression load, predominately in geotechnical applications, lock nuts can be omitted.

However it is important that the two threadbars meet centrally within the coupler and remain so during installation to ensure a correct load transfer.

This can be achieved by using grub screws and a center pin. The right position of the GEWI® Threadbars within the coupler can be checked easily using colored marks.

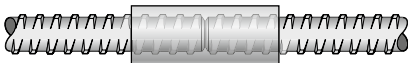

Standard Coupling

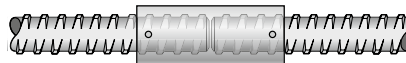

Grub Screws – Optional



Paint – Visual Indicator

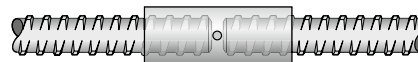

Center Pin – Optional

Anchorage for GEWI® Threadbars

Anchorage which are to be embedded in concrete can be carried out using an anchor nut (hexagonal nut), a steel plate and a lock nut.

In addition, an anchorage can be realized using a flanged nut and a lock nut.

For the connection of GEWI® Threadbars with steel structures, a weldable anchor piece is available.

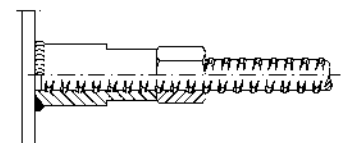
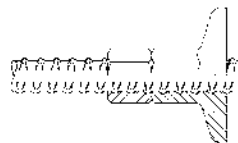
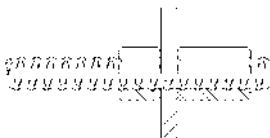

GEWI® Threadbar Accessories

Nominal Diameter	Flat Plate Stock Size *	Hexagonal Nut		Recessed Plate Stock Size*	Domed Nut		Formed Plate Stoke Size *	Hemisphere	
		AF	Length		AF	Length		Dia.	Length
[mm]	[mm]	[mm]	[mm]	[mm]	[mm]	[mm]	[mm]	[mm]	[mm]
16	150 x 150 x 10	32	40	150 x 150 x 30			150 x 150 x 10	46	18
20	150 x 150 x 10	36	45	150 x 150 x 30	35	41	150 x 150 x 10	46	18
25	150 x 150 x 10	41	50	150 x 150 x 30	38	45	150 x 150 x 10	57	23
28	150 x 150 x 10	46	55	200 x 200 x 40	43	54	150 x 150 x 10	57	23
32	200 x 200 x 25	55	60	200 x 200 x 40	46	57		80	33
40	250 x 250 x 40	65	70	250 x 250 x 50				120	55
50	300 x 300 x 40	80	120	300 x 300 x 50				120	60



* Anchor plates can be supplied in any size to suit customer requirements.

Nominal Diameter	Static Coupler(a)		Static Coupler(a)		Dynamic Coupler(b)		Lock Nut		Flanged Anchor Nut			Torque M _T
	Dia.	Length	Dia.	Length	Dia.	Length	AF	Length	AF	Length	Dia.	
[mm]	[mm]	[mm]	[mm]	[mm]	[mm]	[mm]	[mm]	[mm]	[mm]	[mm]	[mm]	[Nm]
16	32	90	34	90	32	115	32	30	30	35	50	200
20	36	105	38	105	32	130	32	40	36	40	60	350
25	40	115	42	115	41	150	41	40	41	45	70	700
28	45	125	48	125	41	170	41	45	46	50	85	950
32	52	140	55	140	50	180	50	50	50	60	100	1,600*
40	65	160	68	160	60	210	65	70	60	70	120	2,900*
50	80	200	84	200	80	240	80	80	80	85	150	8,000*
63.5	102	260	106	260	102	260	90	110	100	115	250	8,000*

* Torque applied to lock nut using hydraulic torque wrench.

(a) Cast coupler

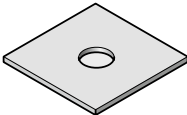
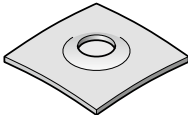
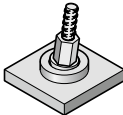
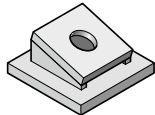
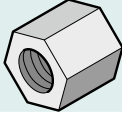
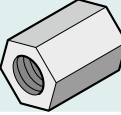
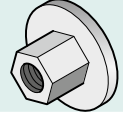
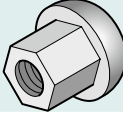
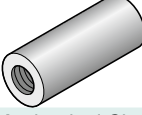
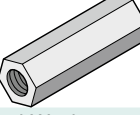
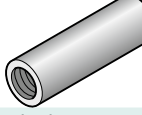
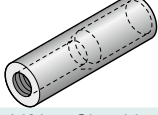
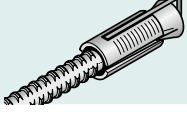
(b) Machined coupler

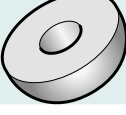
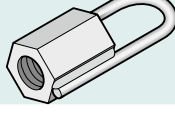
Plates	Flat Plate 	Formed Plate up to 20° 	Articulating Plate up to 30° 	Gusseted Plate up to 45° 
Nuts	Lock Nut 	Hexagonal Nut 	Flanged Nut 	Domed Nut 
Couplers	Static Coupler 	Dynamic Coupler 	Contact Coupler 	Transition Coupler 
Ancillaries	Mechanical Shell 	Tapered Washer up to 15° 	Hemisphere up to 30° 	Lifting Shackles 

Corrosion Protection

- Galvanizing acc. to EN ISO 1461 : 1999
 - Rock Bolts
 - Soil Nails
 - Temporary Ground Anchors
- Double Corrosion Protection acc. to BS 8081 : 1989
 - Permanent Soil Nails
 - Permanent Ground Anchors

GEWI® Threadbar – Connecting Reinforcement

The GEWI® connecting reinforcement consists of prefabricated GEWI® couplers for the use in construction joints.

The transmission of the forces of the construction joint to the reinforcement of the adjacent concrete takes place by bond.

The GEWI® connecting systems with straight reinforcement consist of coupler bars type M and coupler bars type A. These are provided in three standard lengths which cover the range of the required embedment length.

The GEWI® connecting bar type M is to be fixed to the formwork. For this purpose, special plugs are available which can be nailed on the formwork.

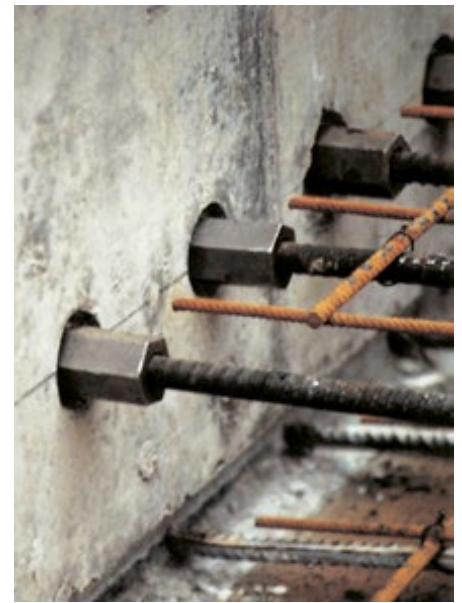

In case of lack of free space, can be shortened the connecting reinforcement by using:

- Hook Bar Type W
- Loop Bar Type S
- End Anchoring Bar Type E.

The GEWI® connecting bar type P is recommended when a load transmission through a reinforced concrete wall is to be realized.

These types of connecting reinforcement are not on stock and will be customized on demand.

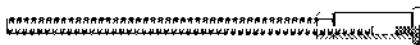

Coupler Bar Type M

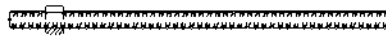

Coupler Bar Type A

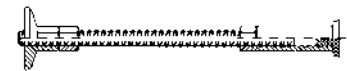

End Anchoring Bar Type E

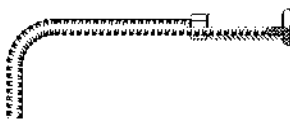

Hook Bar Type W



Connecting Bar Type P

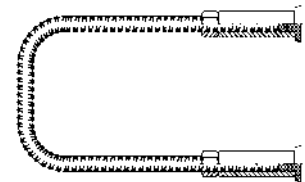

Loop Bar Type S

GEWI® Threadbar – Prefabricated Connecting Reinforcement

Standard Lengths

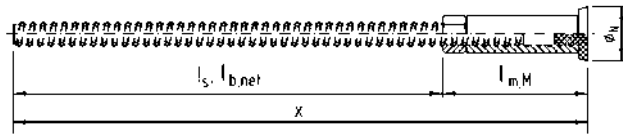

GEWI® Coupler Bar Type M

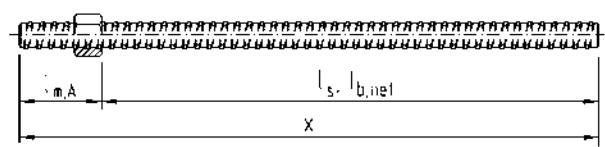

GEWI® Coupler Bar Type A

GEWI® Ø [mm]	Coupler Bar Type M		Lap Length l _{b,net} [cm]	Weight G [kg]	Total Length X [mm]	Length of Coupler Part l _{m,M} [mm]	Lock Nut Standard T 2003		Coupler Standard T 3003		Plug	
	Designation						AF [mm]	L _{Km} [mm]	X [mm]	Length [mm]	X _N [mm]	Thickness [mm]
12	GEWI® M12	36	36	0.53	445	85	19	20	22	60	40	5
		54	54	0.69	625							
		96	96	1.07	1,045							
16	GEWI® M16	55	55	1.58	675	125	32	30	32	90	52	5
		102	102	2.32	1,145							
		183	183	3.60	1,955							
20	GEWI® M20	69	69	2.71	840	150	32	40	36	105	52	5
		128	128	4.16	1,430							
		229	229	6.66	2,440							
25	GEWI® M25	86	86	4.72	1,020	160	41	40	42	115	62	5
		160	160	7.56	1,760							
		286	286	12.42	3,020							
28	GEWI® M28	97	97	6.62	1,145	175	41	45	45	125	62	5
		179	179	10.58	1,965							
		320	320	17.39	3,375							
32	GEWI® M32	111	111	9.91	1,308	198	50	50	52	140	60	8
		205	205	15.84	2,248							
		366	366	26.00	3,858							

GEWI® Ø [mm]	Coupler Bar Type A		Lap Length l _{b,net} [cm]	Weight G [kg]	Total Length X [mm]	Length of Coupler Part l _{m,M} [mm]	Lock Nut Standard T 2003	
	Designation						AF [mm]	L _{Km} [mm]
12	GEWI® A12	36	36	0.40	410	50	19	20
		54	54	0.59	590			
		96	96	1.93	1,010			
16	GEWI® A16	55	55	1.15	625	75	32	30
		102	102	1.89	1,095			
		183	183	3.17	1,905			
20	GEWI® A20	69	69	2.11	783	93	32	40
		128	128	3.57	1,373			
		229	229	6.07	2,383			
25	GEWI® A25	86	86	4.00	960	100	41	40
		160	160	6.85	1,700			
		286	286	11.70	2,960			
28	GEWI® A28	97	97	5.62	1,078	108	41	45
		179	179	9.59	1,898			
		320	320	16.40	3,308			
32	GEWI® A32	111	111	8.41	1,230	120	50	50
		205	205	14.34	2,170			
		366	366	24.50	3,780			

GEWI® Threadbar – Prefabricated Connecting Reinforcement

Customized Products

Hook Bar Type W

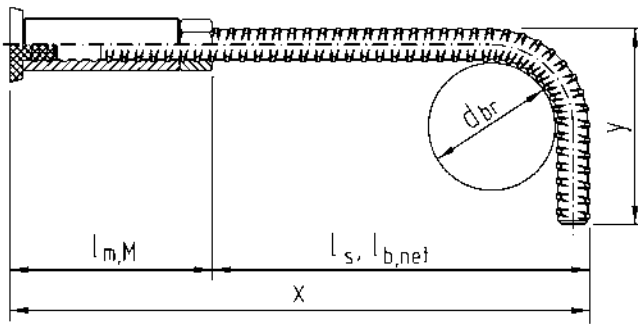

Specifications

GEWI® W \emptyset - x/y/d_{br}

- \emptyset diameter GEWI® BSt 500 S
- x total length
- y hook length
- d_{br} bending diameter

- l_{b, net} anchorage length
- l_{m, M} length of coupler part

Loop Bar Type S

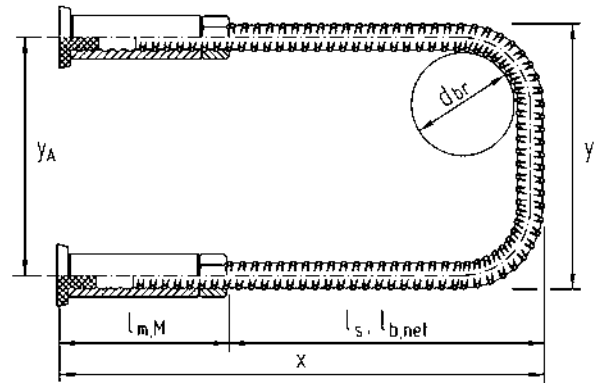

Specifications

GEWI® S \emptyset - x/y/d_{br}

- \emptyset diameter GEWI® BSt 500 S
- x total length
- y loop width
- d_{br} bending diameter

- l_{b, net} anchorage length
- l_{m, M} length of coupler part
- y_A center distance

End Anchorage Bar Type E

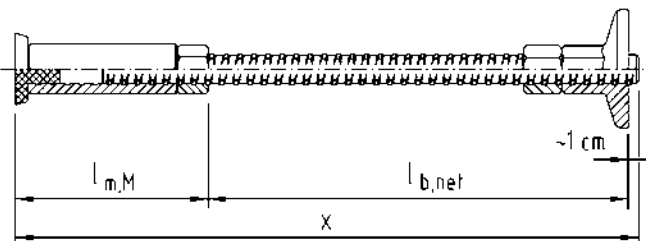

Specifications

GEWI® E \emptyset - x

- \emptyset diameter GEWI® BSt 500 S
- x total length

Connecting Bar Type P

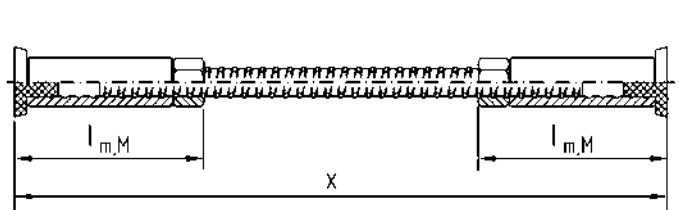

Specifications

GEWI® P \emptyset - x

- \emptyset diameter GEWI® BSt 500 S
- x fitting length

GEWI® Threadbar – Typical Applications for Reinforcing Concrete

Examples for roof connections

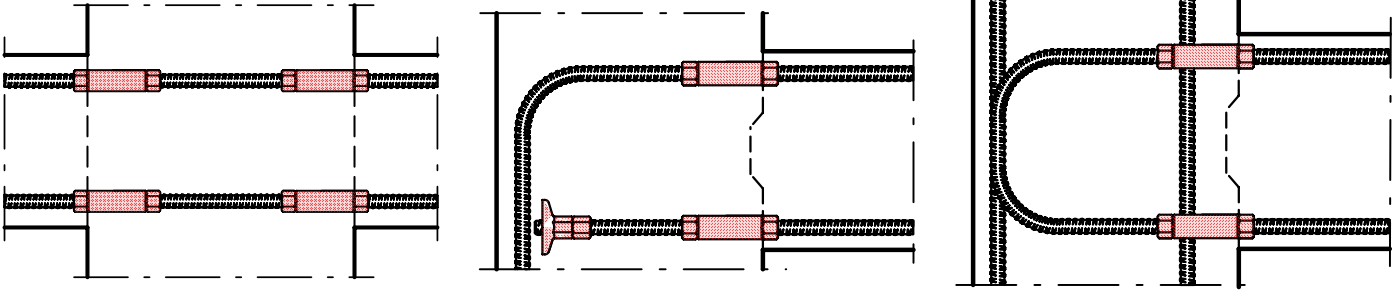

Examples for connecting bending reinforcement

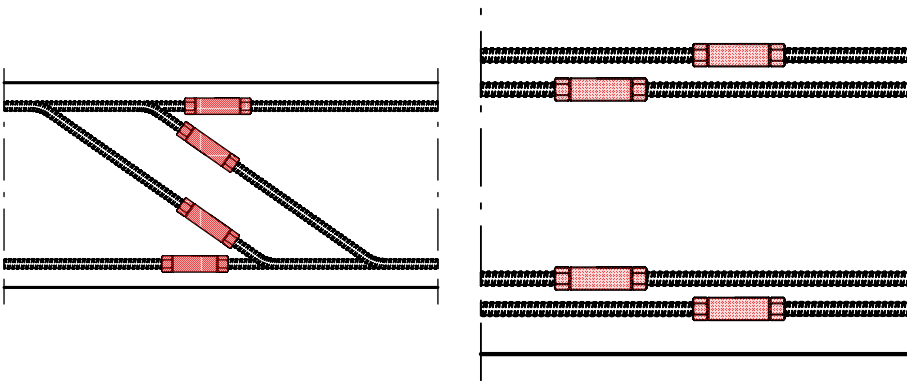

Examples for a fixed column support

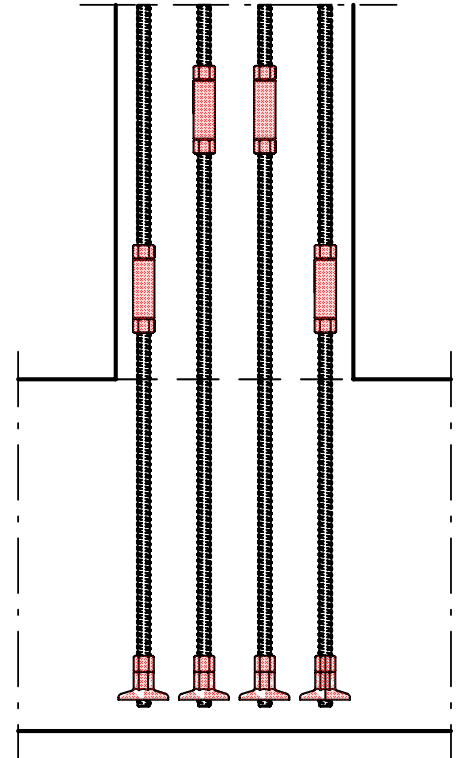

Examples for a frame corner and a consite

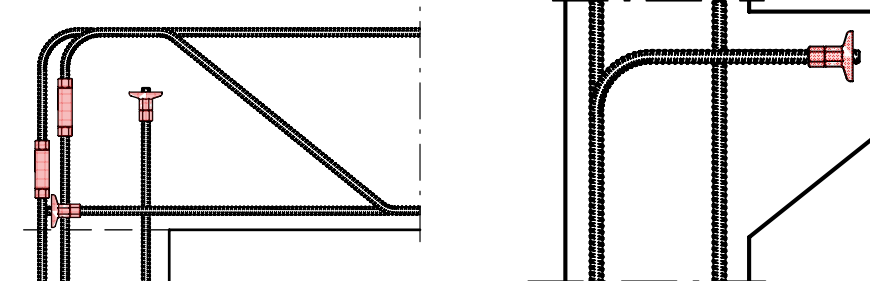

GEWI® Threadbar – Further Applications

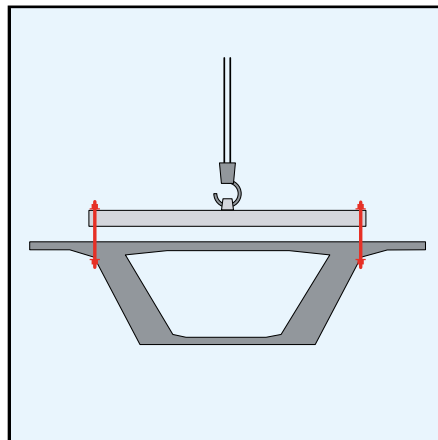
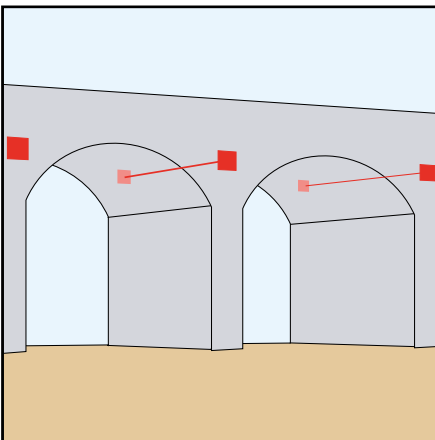

GEWI® Threadbar – Mounting Connecting Reinforcement

The GEWI® connecting reinforcement

- Coupler Bar Type M
- Hook Bar Type W
- Loop Bar Type S
- Anchoring Bar Type E
- Connecting Bar Type P

are delivered with a pre-mounted coupler and are to be fixed to the formwork prior concreting.

GEWI® Threadbar – Assembly Instructions for Couplers

The assembly of GEWI® coupler can be carried out fast and simple in the following way:

1. Marking of the screw-in length at the fifth rib to ensure the turn in of four ribs of the rod.
2. Screwing on a lock nut and a coupler on steel rod 1 and a lock nut on steel rod 2.
3. Joining the steel rods together and screwing up the coupler. Checking with the marking if both steel rods are turned in sufficiently into the coupler.
4. Hand-screwing the lock nuts against the coupler.
5. Locking the nut with the required torque using special torque wrenches.

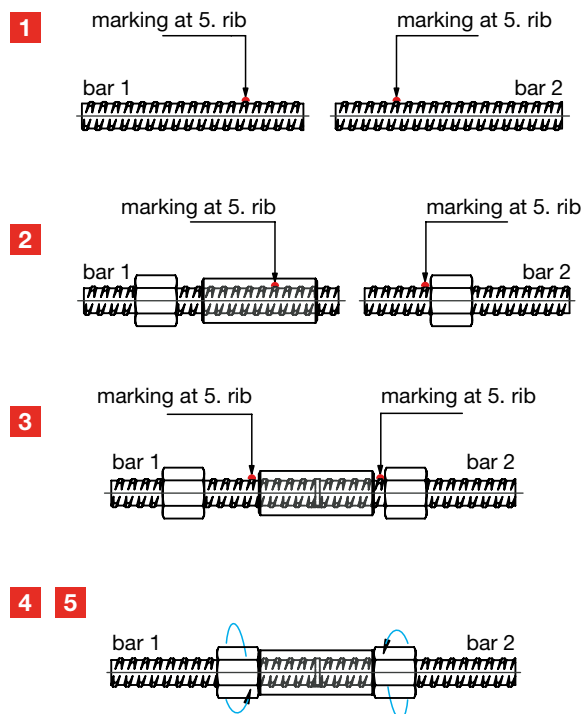

Installation procedure for the GEWI® connecting reinforcement

1. Nail the plug on the formwork in the desired position.
2. Screw on the GEWI® Coupler Bar Type M manually.
3. After the formwork has been demoulded, screw off the plug.
4. Screw in the GEWI® Coupler Bar Type A and lock it with the required torque.

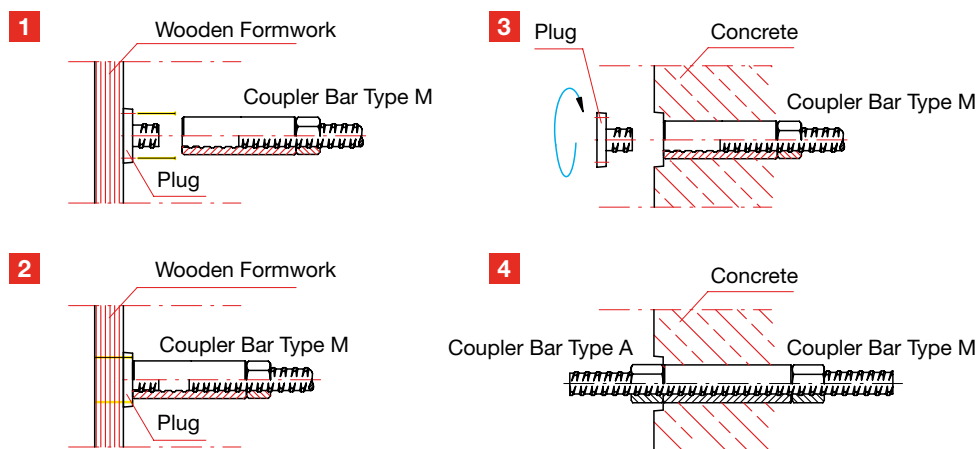

Austria

DSI Underground Austria GmbH
 Alfred-Wagner-Strasse 1
 4061 Pasching/Linz, Austria
 Phone +43-7229-61 04-90
 E-mail office@dywidag-systems.at
 www.dywidag-systems.at

Belgium

DYWIDAG-Systems International N.V.
 Philipssite 5, bus 15
 Ubicenter
 3001 Leuven, Belgium
 Phone +32-16-60 77 60
 E-mail info.be@dywidag-systems.com

Czech Republic

DYWIDAG-Systems International
 Jilemnického 29/46
 772 00 Olomouc-Nedvěži, Czech Republic
 Phone +420-585-94 10 76
 E-mail dsihv@dywidag-systems.com

France

DSI France SAS
 Rue de la Craz
 Z.I. des Chartinières
 01120 Dagneux, France
 Phone +33-4-78 79 27 82
 E-mail dsi.france@dywidag.fr
 www.dywidag-systems.fr

Germany

DYWIDAG-Systems International GmbH
 Schuetzenstrasse 20
 14641 Nauen, Germany
 Phone +49 3321 44 18 0
 E-mail suspa@dywidag-systems.com
 www.dywidag-systems.de

DYWIDAG-Systems International GmbH
 Max-Planck-Ring 1
 40764 Langenfeld, Germany
 Phone +49 2173 79 02 0
 E-mail suspa@dywidag-systems.com
 www.dywidag-systems.de

DYWIDAG-Systems International GmbH
 Germanenstrasse 8
 86343 Koenigsbrunn, Germany
 Phone +49 8231 96 07 0
 E-mail geotechnik@dywidag-systems.com
 www.dywidag-systems.de

DYWIDAG-Systems International GmbH
 Siemensstrasse 8
 85716 Unterschleissheim, Germany
 Phone +49-89-30 90 50-100
 E-mail dsihv@dywidag-systems.com
 www.dywidag-systems.com/emea

Please Note:

This brochure serves basic information purposes only. Technical data and information provided herein shall be considered non-binding and may be subject to change without notice. We do not assume any liability for losses or damages attributed to the use of this technical data and any improper use of our products. Should you require further information on particular products, please do not hesitate to contact us.

Italy

DYWIT S.P.A.
 Viale Europa 72 Strada A 7/9
 20090 Cusago (MI), Italy
 Phone +39-02-901 65 71
 E-mail info@dywit.it
 www.dywit.it

Netherlands

DYWIDAG-Systems International B.V.
 Veilingweg 2
 5301 KM Zaltbommel, Netherlands
 Phone +31-418-57 89 22
 E-mail email.nl@dywidag-systems.com
 www.dywidag-systems.com/emea

Poland

DYWIDAG-SYSTEMS INTERNATIONAL Sp. z o.o.
 ul. Bojowników o Wolność
 i Demokrację 38/121
 41-506 Chorzów, Poland
 Phone +48-58-300 13 53
 E-mail dsi-polska@dywidag-systems.com
 www.dywidag-systems.pl

Portugal

DYWIDAG SISTEMAS CONSTRUCTIVOS, SA
 Rua D. Manuel I, n.º24 A
 Quinta da Parreirinha
 2695-003 Bobadela (Loures), Portugal
 Phone +351-21-89 22 890
 E-mail dywidag@dywidag-sistemas.com

Spain

DYWIDAG SISTEMAS CONSTRUCTIVOS, S.A.
 Avd/de la Industria, 4
 Pol. Ind. la Cantuena
 28947 Fuenlabrada (Madrid), Spain
 Phone +34-91-642 20 72
 E-mail dywidag@dywidag-sistemas.com
 www.dywidag-sistemas.com

United Kingdom

DYWIDAG-Systems International Ltd.
 Northfield Road
 Southam, Warwickshire
 CV47 0FG, Great Britain
 Phone +44-1926-81 39 80
 E-mail sales@dywidag.co.uk
 www.dywidag.co.uk

ARGENTINA
 AUSTRALIA
 AUSTRIA
 BELGIUM
 BOSNIA AND HERZEGOVINA
 BRAZIL
 CANADA
 CHILE
 CHINA
 COLOMBIA
 COSTA RICA
 CROATIA
 CZECH REPUBLIC
 DENMARK
 EGYPT
 ESTONIA
 FINLAND
 FRANCE
 GERMANY
 GREECE
 GUATEMALA
 HONDURAS
 HONG KONG
 INDIA
 INDONESIA
 IRAN
 ITALY
 JAPAN
 KOREA
 LEBANON
 LUXEMBOURG
 MALAYSIA
 MEXICO
 NETHERLANDS
 NIGERIA
 NORWAY
 OMAN
 PANAMA
 PARAGUAY
 PERU
 POLAND
 PORTUGAL
 QATAR
 RUSSIA
 SAUDI ARABIA
 SINGAPORE
 SOUTH AFRICA
 SPAIN
 SWEDEN
 SWITZERLAND
 TAIWAN
 THAILAND
 TURKEY
 UNITED ARAB EMIRATES
 UNITED KINGDOM
 URUGUAY
 USA
 VENEZUELA

www.dywidag-systems.com/emea