

DYWIDAG Marine Tie Rods – Smooth Bars & Walings





Contents

General Information.....	4
Fields of Applications.....	4
Overview of Steel Grades	5
Steel Properties.....	5
Thread Creation	6
Key Advantages of Rolled Threads.....	6
ULS Tie Rod Design According to DIN EN 1993-5	8
Design Example	9
Tie Rod Types	10
Tie Rods with Upset and Rolled Threads acc. to EAU 2014 k_t 0.55.....	10
Tie Rods with Upset and Rolled Threads acc. to DIN EN 1993-5	12
Tie Rods with Rolled Threads acc. to DIN EN 1993-5 k_t 0.9	14
Eye Rods k_t 0.6	16
Tie Rod Connection Elements	18
Turnbuckles for Tie Rods	18
Couplers for Tie Rods	18
Hinged Turnbuckles for Tie Rods.....	20
Hexagonal Nuts*	20
Domed Nuts*	20
Shackle Joint for Tie Rods	22
Rocker Plate for Tie Rods	22
Threaded Rocker Plate for Tie Rods	22
Universal Joints for Tie Rods	24
Universal Joints at Waling for Tie Rods.....	24
Tie Rod and Waling Joints	26
Rear Plate for DSI 355 Tie Rods acc. to 1993-5 with k_t 0.9 in S355.....	26
Rear Plate for DSI 460 Tie Rods acc. to 1993-5 with k_t 0.9 in S355.....	28
Rear Plate for DSI 500 Tie Rods acc. to 1993-5 with k_t 0.9 in S355.....	30
Rear Plate for DSI 720 Tie Rods.....	32
T-Connections for Tie Rods*	34
T-Connections in Combined Sheet Piling for Anchors*.....	34
Typical Complete Tie Rod Systems	36
Compensate for Shallow Angles of up to max. 5°.....	36
Dead Man.....	36
Combined Sheet Piling with Tubular Piles.....	36
Combined Sheet Piling when using Grade DSI 720.....	36
Anchors Connected to Tubular Piles.....	37
Heavy-Duty Walls with Steel Sections	37
Alternative Tubular Pile Connection Option Permitting Rotational Movement in all Directions.....	37
Walings	38
Waling Splice Joint.....	39
Waling Bracket.....	40
Waling Bolt with Head and Nut	41
Waling Stud with two Nuts.....	42
Appendix	43
List of Standards and Directives	43

General Information

Deep vertical shoring systems for marine structures such as sheet pile walls often require additional anchors which support a specific layer of the shoring wall. These anchors are also referred to as tie rods. They transfer the supportive forces at the connection

with the sheet pile wall via tension loads either to a dead man anchorage or to the other shoring wall side in the case of wharf sheet pile boxes. Typically, the horizontal reaction forces are transferred from the sheet pile walls first to a waling beam and then from the waling system

to the tie rods. This setup leads to a more distributed load transfer and an additional stiffening and alignment of the sheet pile wall compared to a solution in which the tie rods are directly connected to the sheet pile wall.

Fields of Applications

Tie Back Retaining Wall with Dead Man

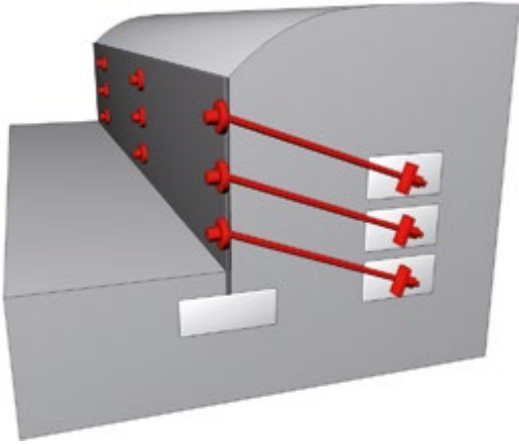

Bracing for Grade Separation

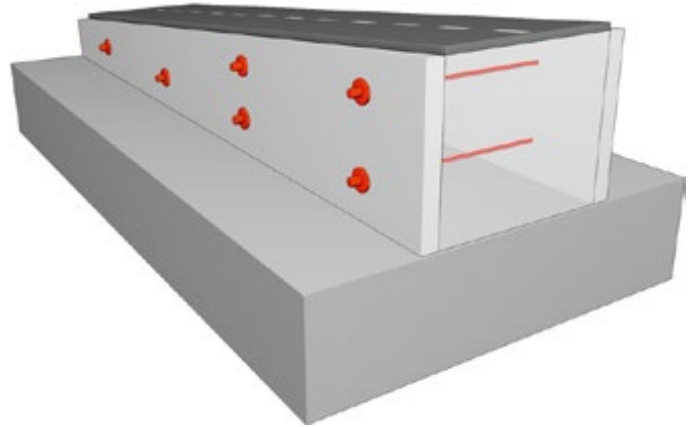

Tie Rods for Sheet Pile Constructed Wharf

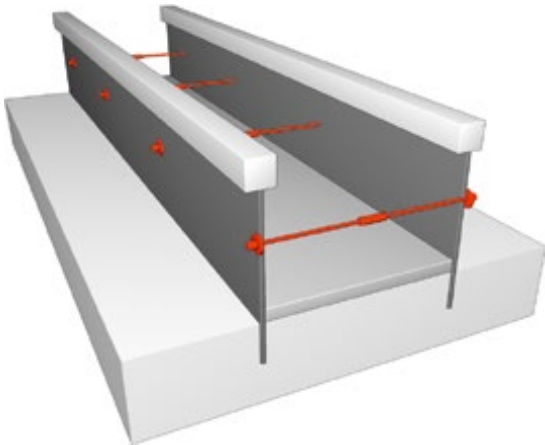

Roadway Embankment Stabilization

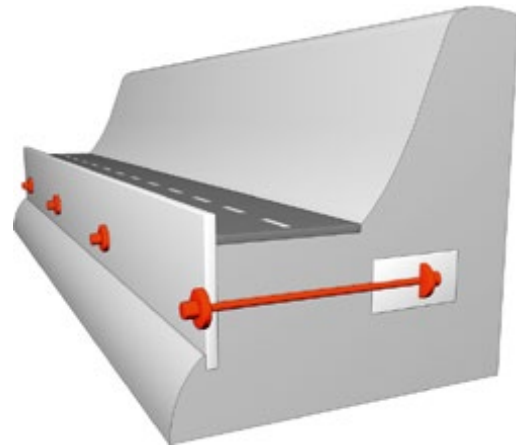

General Information

Overview of Steel Grades

Color Code	Steel Grade	Diameter [$\varnothing D_1$]	F_y [N/mm ²]	F_{ua} [N/mm ²]
	DSI 355	M39 - M160	355	510
	DSI 460	M39 - M160	460	640
	DSI 500	M39 - M160	500	680
	DSI 720	M39 - M160	720	900

F_y = Characteristic Yield Stress
 F_{ua} = Characteristic Failure Stress

Steel Characteristics

The steel used for our marine tie rods is based on the continuous casting method production leading to a homogenous resistance behavior over the entire steel section area.

Steel Properties

DSI 355

- Typical structural steel acc. to EN 10025
- Forged materials available in all lengths
- CE marking and declaration possible

DSI 460

- Fine-grained structural steel acc. to EN 10025
- Easy-to-process steel grade limit acc. to EN 1993-5
- Forged materials available in all lengths
- CE marking and declaration possible

DSI 500

- Steel modified from DSI 460
- All further properties as for DSI 460
- Forged materials available in all lengths
- CE marking and declaration possible

DSI 720

- Maximum length up to 12m
- CE marking upon request
- Forged materials available up to 12 m length
- Classic QT steel acc. to DIN EN 10083-1 and quenched and tempered to achieve grade 10.9 acc. to EN ISO 898-1

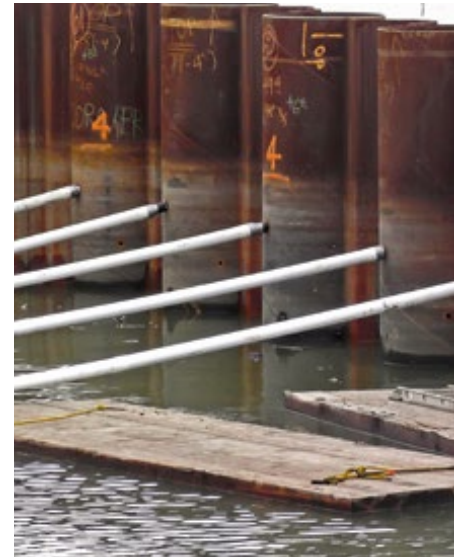

General Information

Thread Creation

All threads are rolled threads. There is no peeling of the bar surface before the thread rolling process. As a result there are no interruptions to the steel fibres, which leads to an additional strengthening of the surface.

On a solid bar any Thread Length is possible. Both, metric and inch threads can be generated. Especially the inch thread shows on-site benefits such as simpler and faster installation progress.

After rolling the thread, the outside diameter of the thread is larger than the diameter of the original steel bar. This leads to a higher load bearing capacity within the thread area compared to a machined thread as this can be seen in the picture below.

Key Advantages of Rolled Threads

- Rolled threads lead to a better profile accuracy than machined threads.
- By rolling the thread, the steels gets cold-formed. This increases the strength of the steel at the roots and flanks of the thread.
- Compared to machined threads, fibres within the steel matrix are not interrupted in case of rolled or hot rolled threads.
- Rolled threads lead to a better dynamic load behavior than machined threads
- Nuts, couplers and turnbuckles typically have machined threads since these load bearing parts (internal threads) are always subject to lower stress levels compared to the corresponding external thread of the tie rod part.

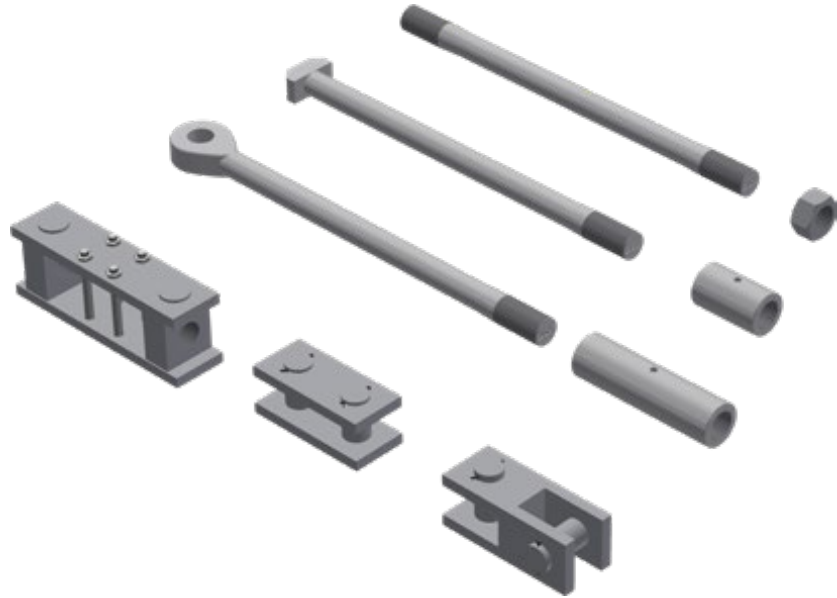

Rolled Thread

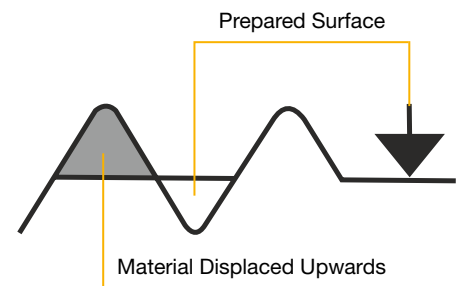
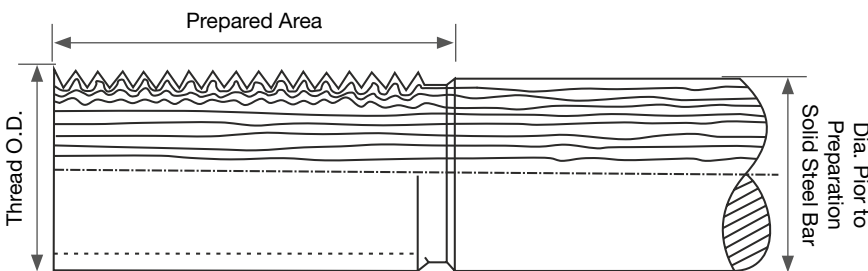

Machined Thread

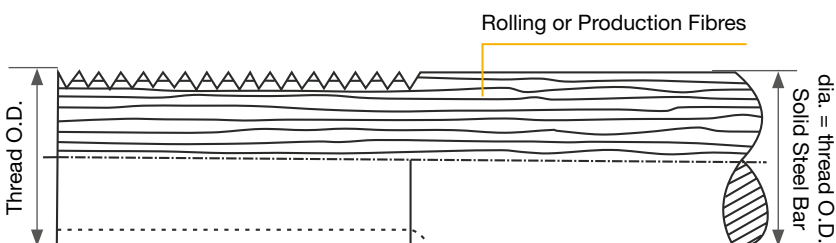



General Information

ULS Tie Rod Design According to DIN EN 1993-5

Symbol	Description
$F_{tt,Rd}$	Design tensile resistance of anchor thread
$F_{tg,Rd}$	Design tensile resistance of anchor shaft
$F_{yt,Rd}$	Design resistance at yield stress / 0.2% proof stress of anchor thread
$F_{yg,Rd}$	Design resistance at yield stress / 0.2% proof stress of anchor shaft
k_t	Notch factor
f_{ua}	Tensile strength of anchor
f_y	Yield stress of anchor
A_s	Stressed cross-sectional area, thread
A_g	Gross cross-sectional area, shaft
γ_{M2}	= 1.25 (Partial safety factor for anchor shaft stressed up to failure, EN 1993-5, 7.2.3)
γ_{M0}	= 1.00 (Partial safety factor for anchor shaft, EN 1993-5, 7.2.3)
$\gamma_{Mt,ser}$	= 1.10 (Partial safety factor SLS verification, EN 1993-5, 7.2.4)

Characteristic	Formula
Design Resistance, Thread	$F_{t,Rd} = \min(F_{tt,Rd} ; F_{yt,Rd})$
Failure in Thread	$F_{tt,Rd} = k_t \cdot f_{ua} \cdot A_s / \gamma_{M2}$
Yield Stress, Thread	$F_{yt,Rd} = f_y \cdot A_s / \gamma_{M0}$
Design Resistance, Shaft	$F_{g,Rd} = \min(F_{tg,Rd} ; F_{yg,Rd})$
Failure in Shaft	$F_{tg,Rd} = A_g \cdot f_{ua} / \gamma_{M2}$
Yield Stress, Shaft	$F_{yg,Rd} = f_y \cdot A_g / \gamma_{M0}$
Design Resistance, Anchor	$F_{u,Rd} = \min(F_{t,Rd} ; F_{g,Rd})$



General Information

Design Example

Design Conditions

- Ultimate Limit State (ULS) load for tie rod
 - $F_{Ed} = 2,500[\text{kN}]$
- Serviceability Limit State (SLS) load
 - $F_{t,ser} = 1,600[\text{kN}]$
- Tie bar length
 - 40m
- Tie bar elongation limit (SLS)
 - 80[mm]
- Design life of structure
 - 50 years
- Notching factor in thread area – use recommended value $k_t = 0.6$ (see BS EN 1993-5 NA A1)

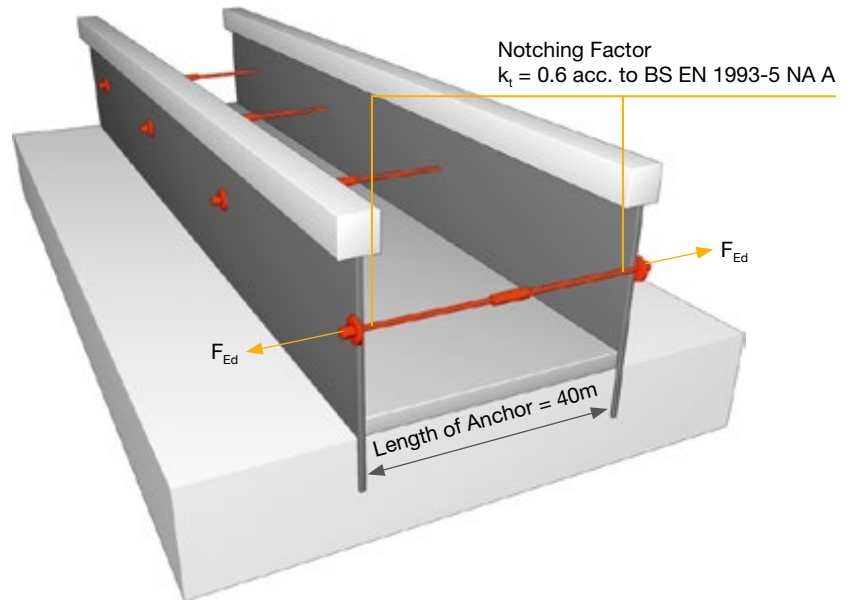

Tie Rod Type Selection

The required minimum anchor size depends on the design tensile resistance $F_{t,Rd} = \min(F_{tt,Rd}; F_{yt,Rd})$ according to EN 1993-5, 7.2.3. The used partial safety factor for the design level are given in the formulation above. The UK decision for the values of the thread notch factor, given in BS EN 1993-5, NA Table A1 Subclause 7.2.3 (2) are:

- The recommended value for k_t is $k_t = 0.6$. This is motivated for cases where possible bending in the anchor as an effect of actions is not made explicit.
- Only in cases where the structural detailing of the location where the anchor rod is joined to the wall is such that bending moments are avoided at that location, the recommended value for k_t may be chosen as $k_t = 0.9$.

Based on the design resistance values of tie rods with rolled threads, tie rod type M105/81 is chosen to fit directly the design tensile resistance conditions in the Ultimate Limit State.

- Thread
 - M105 (stress area $A_S: 7,755[\text{mm}^2]$)
- Shaft
 - 81[mm] (stress area $A_y: 5,153[\text{mm}^2]$)
- Yield Stress of the Anchor
 - $f_y = 500[\text{N}/\text{mm}^2]$
- Tensile Strength of Anchor
 - $f_{ua} = 680[\text{N}/\text{mm}^2]$

Serviceability Limit State (SLS) Check acc. to EN 1993-5, 7.2.4

Elongation under SLS loading condition.

1. Stress in shaft, $\sigma_t = F_{t,ser}/A_g = 1,600 * 10^3/5,153 = 310[\text{N}/\text{mm}^2]$

2. Elongation = $\sigma_t * \text{Length}/E\text{-Modul} = 310 * 400/2,100 = 59[\text{mm}] < 80[\text{mm}]$

Note: If the elongation is exceeding the limit of 80[mm], try a larger diameter of a less grade.

3. Yield Stress, Thread = $F_{yt,Rd} = f_y * \min(A_S; A_g)/\gamma_{Mt,ser} = 500 * 7,755/(1.1 * 10^3) = 3,525[\text{kN}] > 1,600[\text{kN}] = F_{t,ser}$

Ultimate Limit State (ULS) check acc. to EN 1993-5, 7.2.3

1. Design tensile resistance = $F_{t,Rd} = 2,531[\text{kN}] > 2,500[\text{kN}] = F_{Ed}$

Tie Rod Types

Tie Rods with Upset and Rolled Threads acc. to EAU 2014 k_t 0.55

Nominal Diameter	$\varnothing D_1$	Metric	M39	M42	M45	M48	M52	M56	M60	M64	M68	M72	M76
Area, Core Diameter	A_s	[mm ²]	976	1,121	1,306	1,473	1,758	2,030	2,362	2,676	3,055	3,460	3,889
Shaft Diameter	d	[mm]	36	39	42	45	38	41	44	47	50	54	57
Area, Shaft	A_g	[mm ²]	1,017	1,194	1,385	1,590	1,134	1,320	1,521	1,735	1,963	2,290	2,552

DSI 355 – Anchor Force to EAU 2014, k_t 0.55			M39	M42	M45	M48	M52	M56	M60	M64	M68	M72	M76
Design Resistance, Shaft	$F_{g,Rd}$	[kN]	328	385	447	513	366	426	491	560	634	739	824
Design Resistance, Thread	$F_{t,Rd}$	[kN]	205	235	275	309	371	428	500	565	648	736	830
Permissible Design Resistance	$F_{u,Rd}$	[kN]	205	235	275	309	366	426	491	560	634	739	824

DSI 460 – Anchor Force to EAU 2014, k_t 0.55			M39	M42	M45	M48	M52	M56	M60	M64	M68	M72	M76
Design Resistance, Shaft	$F_{g,Rd}$	[kN]	425	499	579	665	474	552	636	726	821	958	1,067
Design Resistance, Thread	$F_{t,Rd}$	[kN]	257	294	345	387	465	537	627	709	813	924	1,042
Permissible Design Resistance	$F_{u,Rd}$	[kN]	257	294	345	387	465	537	627	709	813	924	1,042

DSI 500 – Anchor Force to EAU 2014, k_t 0.55			M39	M42	M45	M48	M52	M56	M60	M64	M68	M72	M76
Design Resistance, Shaft	$F_{g,Rd}$	[kN]	462	542	629	723	516	600	691	789	892	1,041	1,160
Design Resistance, Thread	$F_{t,Rd}$	[kN]	273	313	366	412	494	570	666	754	864	982	1,107
Permissible Design Resistance	$F_{u,Rd}$	[kN]	273	313	366	412	494	570	666	754	864	982	1,107



M80	M85	M90	M95	M100	M105	M110	M115	M120	M125	M130	M135	M140	M145	M150	M155	M160
4,344	4,948	5,591	6,273	6,995	7,755	8,556	9,395	10,274	11,191	12,149	13,145	14,181	15,256	16,370	17,524	18,716
60	64	68	73	77	81	85	89	93	97	101	105	109	113	118	123	127
2,827	3,217	3,632	4,185	4,657	5,153	5,675	6,221	6,793	7,390	8,012	8,659	9,331	10,029	10,936	11,882	12,668

M80	M85	M90	M95	M100	M105	M110	M115	M120	M125	M130	M135	M140	M145	M150	M155	M160
912	1,038	1,172	1,351	1,503	1,663	1,831	2,008	2,192	2,385	2,586	2,795	3,011	3,237	3,529	3,835	4,088
930	1,062	1,204	1,354	1,512	1,680	1,857	2,042	2,236	2,439	2,651	2,871	3,101	3,339	3,586	3,842	4,106
912	1,038	1,172	1,351	1,503	1,663	1,831	2,008	2,192	2,385	2,586	2,795	3,011	3,237	3,529	3,835	4,088

M80	M85	M90	M95	M100	M105	M110	M115	M120	M125	M130	M135	M140	M145	M150	M155	M160
1,182	1,345	1,519	1,750	1,947	2,155	2,373	2,602	2,841	3,090	3,350	3,621	3,902	4,194	4,573	4,969	5,297
1,167	1,333	1,510	1,699	1,898	2,108	2,330	2,562	2,806	3,061	3,326	3,603	3,891	4,190	4,500	4,821	5,153
1,167	1,333	1,510	1,699	1,898	2,108	2,330	2,562	2,806	3,061	3,326	3,603	3,891	4,190	4,500	4,821	5,153

M80	M85	M90	M95	M100	M105	M110	M115	M120	M125	M130	M135	M140	M145	M150	M155	M160
1,285	1,462	1,651	1,902	2,117	2,342	2,579	2,828	3,088	3,359	3,642	3,936	4,242	4,559	4,971	5,401	5,758
1,240	1,416	1,605	1,805	2,017	2,240	2,476	2,723	2,981	3,252	3,534	3,828	4,134	4,452	4,781	5,122	5,475
1,240	1,416	1,605	1,805	2,017	2,240	2,476	2,723	2,981	3,252	3,534	3,828	4,134	4,452	4,781	5,122	5,475



Tie Rod Types

Tie Rods with Upset and Rolled Threads acc. to DIN EN 1993-5

Nominal Diameter	$\varnothing D_1$	Metric	M39	M42	M45	M48	M52	M56	M60	M64	M68	M72	M76
Stressed Area, Thread	A_s	[mm ²]	976	1,121	1,306	1,473	1,758	2,030	2,362	2,676	3,055	3,460	3,889
Shaft Diameter	d	[mm]	36	39	42	45	38-39	41-42	44-46	47-50	50-54	54-58	57-62

DSI 355 – Anchor Force to EN 1993-5, k_t 0.6			M39	M42	M45	M48	M52	M56	M60	M64	M68	M72	M76
Shaft Diameter	d	[mm]	36	39	42	45	38	41	44	47	50	54	57
Area, Shaft	A_g	[mm ²]	1,018	1,195	1,385	1,590	1,134	1,320	1,521	1,735	1,963	2,290	2,552
Design Resistance, Shaft	$F_{g,Rd}$	[kN]	361	424	492	565	403	469	540	616	697	813	906
Design Resistance, Thread	$F_{t,Rd}$	[kN]	239	274	320	361	430	497	578	655	748	847	952
Permissible Design Resistance	$F_{u,Rd}$	[kN]	239	274	320	361	403	469	540	616	697	813	906

DSI 355 – Anchor Force to EN 1993-5, k_t 0.9			M39	M42	M45	M48	M52	M56	M60	M64	M68	M72	M76
Shaft Diameter	d	[mm]	36	39	42	45	39	42	46	50	54	58	62
Area, Shaft	A_g	[mm ²]	1,018	1,195	1,385	1,590	1,195	1,385	1,662	1,963	2,290	2,642	3,019
Design Resistance, Shaft	$F_{g,Rd}$	[kN]	361	424	492	565	424	492	590	697	813	938	1,072
Design Resistance, Thread	$F_{t,Rd}$	[kN]	346	398	464	523	624	721	839	950	1,085	1,228	1,381
Permissible Design Resistance	$F_{u,Rd}$	[kN]	346	398	464	523	424	492	590	697	813	938	1,072

DSI 460 – Anchor Force to EN 1993-5, k_t 0.6			M39	M42	M45	M48	M52	M56	M60	M64	M68	M72	M76
Shaft Diameter	d	[mm]	36	39	42	45	38	41	44	47	50	54	57
Area, Shaft	A_g	[mm ²]	1,018	1,195	1,385	1,590	1,134	1,320	1,521	1,735	1,963	2,290	2,552
Design Resistance, Shaft	$F_{g,Rd}$	[kN]	468	550	637	732	522	607	699	798	903	1,054	1,174
Design Resistance, Thread	$F_{t,Rd}$	[kN]	300	344	401	453	540	624	726	822	938	1,063	1,195
Permissible Design Resistance	$F_{u,Rd}$	[kN]	300	344	401	453	522	607	699	798	903	1,054	1,174

DSI 460 – Anchor Force to EN 1993-5, k_t 0.9			M39	M42	M45	M48	M52	M56	M60	M64	M68	M72	M76
Shaft Diameter	d	[mm]	36	39	42	45	39	42	46	50	54	58	62
Area, Shaft	A_g	[mm ²]	1,018	1,195	1,385	1,590	1,195	1,385	1,662	1,963	2,290	2,642	3,019
Design Resistance, Shaft	$F_{g,Rd}$	[kN]	468	550	637	732	550	637	764	903	1,054	1,215	1,389
Design Resistance, Thread	$F_{t,Rd}$	[kN]	449	516	601	678	809	934	1,087	1,231	1,405	1,592	1,789
Permissible Design Resistance	$F_{u,Rd}$	[kN]	449	516	601	678	550	637	764	903	1,054	1,215	1,389

DSI 500 – Anchor Force to EN 1993-5, k_t 0.6			M39	M42	M45	M48	M52	M56	M60	M64	M68	M72	M76
Shaft Diameter	d	[mm]	36	39	42	45	38	41	44	47	50	54	57
Area, Shaft	A_g	[mm ²]	1,018	1,195	1,385	1,590	1,134	1,320	1,521	1,735	1,963	2,290	2,552
Design Resistance, Shaft	$F_{g,Rd}$	[kN]	509	597	693	795	567	660	760	867	982	1,145	1,276
Design Resistance, Thread	$F_{t,Rd}$	[kN]	319	366	426	481	574	663	771	873	997	1,129	1,269
Permissible Design Resistance	$F_{u,Rd}$	[kN]	319	366	426	481	567	660	760	867	982	1,129	1,269

DSI 500 – Anchor Force to EN 1993-5, k_t 0.9			M39	M42	M45	M48	M52	M56	M60	M64	M68	M72	M76
Shaft Diameter	d	[mm]	36	39	42	45	39	42	46	50	54	58	62
Area, Shaft	A_g	[mm ²]	1,018	1,195	1,385	1,590	1,195	1,385	1,662	1,963	2,290	2,642	3,019
Design Resistance, Shaft	$F_{g,Rd}$	[kN]	509	597	693	795	597	693	831	982	1,145	1,321	1,510
Design Resistance, Thread	$F_{t,Rd}$	[kN]	478	549	639	721	861	994	1,156	1,310	1,496	1,694	1,904
Permissible Design Resistance	$F_{u,Rd}$	[kN]	478	549	639	721	597	693	831	982	1,145	1,321	1,510



M80	M85	M90	M95	M100	M105	M110	M115	M120	M125	M130	M135	M140	M145	M150	M155	M160
4,344	4,948	5,591	6,273	6,995	7,755	8,556	9,395	10,274	11,191	12,149	13,145	14,181	15,256	16,370	17,524	18,716
60-66	64-71	68-75	73-80	77-85	81-90	85-95	89-100	93-105	97-110	100-115	105-120	110-125	115-130	120-135	125-140	130-145

M80	M85	M90	M95	M100	M105	M110	M115	M120	M125	M130	M135	M140	M145	M150	M155	M160
60	64	68	73	77	81	85	89	93	97	100	105	110	115	120	125	130
2,827	3,217	3,632	4,185	4,657	5,153	5,675	6,221	6,793	7,390	7,854	8,659	9,503	10,387	11,310	12,272	13,273
1,004	1,142	1,289	1,486	1,653	1,829	2,014	2,209	2,411	2,623	2,788	3,074	3,374	3,687	4,015	4,357	4,712
1,063	1,211	1,369	1,536	1,712	1,898	2,095	2,300	2,515	2,740	2,974	3,218	3,472	3,735	4,007	4,290	4,582
1,004	1,142	1,289	1,486	1,653	1,829	2,014	2,209	2,411	2,623	2,788	3,074	3,374	3,687	4,007	4,290	4,582

M80	M85	M90	M95	M100	M105	M110	M115	M120	M125	M130	M135	M140	M145	M150	M155	M160
66	71	75	80	85	90	95	100	105	110	115	120	125	130	135	140	145
3,421	3,959	4,418	5,027	5,675	6,362	7,088	7,854	8,659	9,503	10,387	11,310	12,272	13,273	14,314	15,394	16,513
1,215	1,406	1,568	1,784	2,014	2,258	2,516	2,788	3,074	3,374	3,687	4,015	4,357	4,712	5,081	5,465	5,862
1,542	1,757	1,985	2,227	2,483	2,753	3,037	3,335	3,647	3,973	4,313	4,666	5,034	5,416	5,811	6,221	6,644
1,215	1,406	1,568	1,784	2,014	2,258	2,516	2,788	3,074	3,374	3,687	4,015	4,357	4,712	5,081	5,465	5,862

M80	M85	M90	M95	M100	M105	M110	M115	M120	M125	M130	M135	M140	M145	M150	M155	M160
60	64	68	73	77	81	85	89	93	97	100	105	110	115	120	125	130
2,827	3,217	3,632	4,185	4,657	5,153	5,675	6,221	6,793	7,390	7,854	8,659	9,503	10,387	11,310	12,272	13,273
1,301	1,480	1,671	1,925	2,142	2,370	2,610	2,862	3,125	3,399	3,613	3,983	4,372	4,778	5,202	5,645	6,106
1,334	1,520	1,718	1,927	2,149	2,382	2,628	2,886	3,156	3,438	3,732	4,038	4,356	4,687	5,029	5,383	5,750
1,301	1,480	1,671	1,925	2,142	2,370	2,610	2,862	3,125	3,399	3,613	3,983	4,356	4,687	5,029	5,383	5,750

M80	M85	M90	M95	M100	M105	M110	M115	M120	M125	M130	M135	M140	M145	M150	M155	M160
66	71	75	80	85	90	95	100	105	110	115	120	125	130	135	140	145
3,421	3,959	4,418	5,027	5,675	6,362	7,088	7,854	8,659	9,503	10,387	11,310	12,272	13,273	14,314	15,394	16,513
1,574	1,821	2,032	2,312	2,610	2,926	3,261	3,613	3,983	4,372	4,778	5,202	5,645	6,106	6,584	7,081	7,596
1,998	2,276	2,572	2,886	3,218	3,567	3,936	4,322	4,726	5,148	5,589	6,047	6,523	7,018	7,530	8,061	8,609
1,574	1,821	2,032	2,312	2,610	2,926	3,261	3,613	3,983	4,372	4,778	5,202	5,645	6,106	6,584	7,081	7,596

M80	M85	M90	M95	M100	M105	M110	M115	M120	M125	M130	M135	M140	M145	M150	M155	M160
60	64	68	73	77	81	85	89	93	97	100	105	110	115	120	125	130
2,827	3,217	3,632	4,185	4,657	5,153	5,675	6,221	6,793	7,390	7,854	8,659	9,503	10,387	11,310	12,272	13,273
1,414	1,608	1,816	2,093	2,328	2,576	2,837	3,111	3,396	3,695	3,927	4,330	4,752	5,193	5,655	6,136	6,637
1,418	1,615	1,825	2,048	2,283	2,531	2,793	3,067	3,353	3,653	3,965	4,291	4,629	4,980	5,343	5,720	6,109
1,414	1,608	1,816	2,048	2,283	2,531	2,793	3,067	3,353	3,653	3,927	4,291	4,629	4,980	5,343	5,720	6,109

M80	M85	M90	M95	M100	M105	M110	M115	M120	M125	M130	M135	M140	M145	M150	M155	M160
66	71	75	80	85	90	95	100	105	110	115	120	125	130	135	140	145
3,421	3,959	4,418	5,027	5,675	6,362	7,088	7,854	8,659	9,503	10,387	11,310	12,272	13,273	14,314	15,394	16,513
1,711	1,980	2,209	2,513	2,837	3,181	3,544	3,927	4,330	4,752	5,193	5,655	6,136	6,637	7,157	7,697	8,256
2,127	2,423	2,737	3,071	3,425	3,797	4,189	4,600	5,030	5,479	5,948	6,436	6,943	7,469	8,015	8,580	9,163
1,711	1,980	2,209	2,513	2,837	3,181	3,544	3,927	4,330	4,752	5,193	5,655	6,136	6,637	7,157	7,697	8,256

Tie Rod Types

Tie Rods with Rolled Threads acc. to DIN EN 1993-5 k_t 0.9

Nominal Diameter	$\varnothing D_1$	Metric	M39	M42	M45	M48	M52	M56	M60	M64	M68	M72	M76
Stressed Area, Thread	A_s	[mm ²]	976	1,121	1,306	1,473	1,758	2,030	2,362	2,676	3,055	3,460	3,889
Shaft Diameter	d	[mm]	36	39	42	45	49	52	56	60	64	68	72
Area, Shaft	A_g	[mm ²]	1,018	1,195	1,385	1,590	1,847	2,124	2,463	2,827	3,217	3,632	4,072

DSI 355 – Anchor Force to EN 1993-5, k_t 0.9			M39	M42	M45	M48	M52	M56	M60	M64	M68	M72	M76
Design Resistance, Shaft	$F_{g,Rd}$	[kN]	361	424	492	565	656	754	874	1,004	1,142	1,289	1,445
Design Resistance, Thread	$F_{t,Rd}$	[kN]	346	397	463	522	624	720	838	949	1,084	1,228	1,380
Max. Design Resistance	$F_{u,Rd}$	[kN]	346	397	463	522	624	720	838	949	1,084	1,228	1,380

DSI 460 – Anchor Force to EN 1993-5, k_t 0.9			M39	M42	M45	M48	M52	M56	M60	M64	M68	M72	M76
Design Resistance, Shaft	$F_{g,Rd}$	[kN]	468	550	637	732	850	977	1,133	1,301	1,480	1,671	1,873
Design Resistance, Thread	$F_{t,Rd}$	[kN]	448	515	600	677	808	933	1,086	1,230	1,405	1,591	1,788
Max. Design Resistance	$F_{u,Rd}$	[kN]	448	515	600	677	808	933	1,086	1,230	1,405	1,591	1,788

DSI 500 – Anchor Force to EN 1993-5, k_t 0.9			M39	M42	M45	M48	M52	M56	M60	M64	M68	M72	M76
Design Resistance, Shaft	$F_{g,Rd}$	[kN]	509	597	693	795	924	1,062	1,232	1,414	1,608	1,816	2,036
Design Resistance, Thread	$F_{t,Rd}$	[kN]	477	548	639	721	860	993	1,156	1,310	1,495	1,694	1,904
Max. Design Resistance	$F_{u,Rd}$	[kN]	477	548	639	721	860	993	1,156	1,310	1,495	1,694	1,904

DSI 720 – Anchor Force to EN 1993-5, k_t 0.9			M39	M42	M45	M48	M52	M56	M60	M64	M68	M72	M76
Design Resistance, Shaft	$F_{g,Rd}$	[kN]	733	860	998	1,145	1,330	1,529	1,773	2,036	2,316	2,615	2,931
Design Resistance, Thread	$F_{t,Rd}$	[kN]	632	726	846	954	1,139	1,315	1,530	1,734	1,979	2,242	2,520
Max. Design Resistance	$F_{u,Rd}$	[kN]	632	726	846	954	1,139	1,315	1,530	1,734	1,979	2,242	2,520

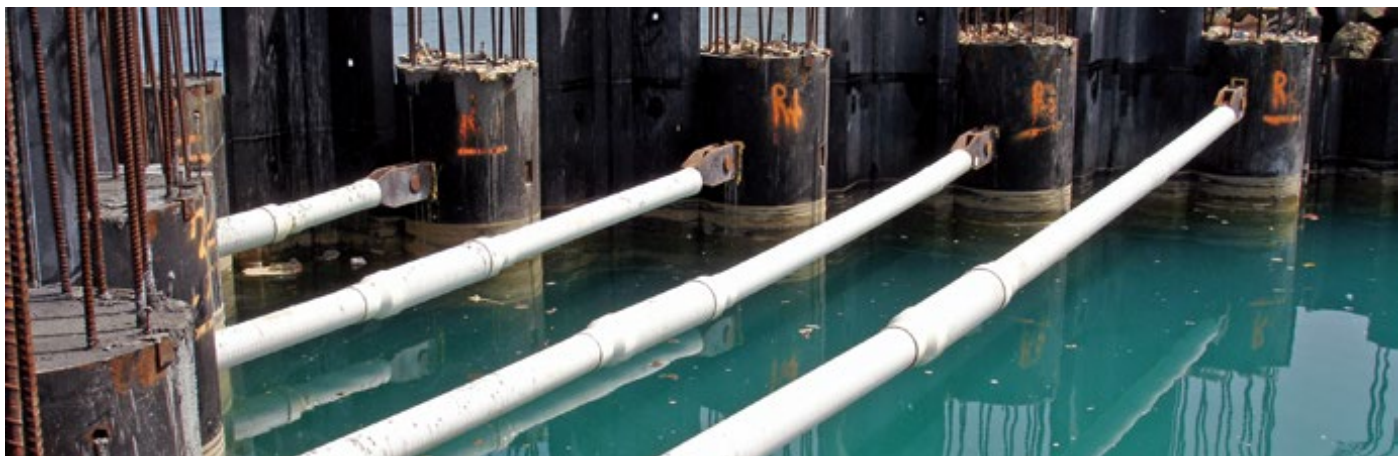



M80	M85	M90	M95	M100	M105	M110	M115	M120	M125	M130	M135	M140	M145	M150	M155	M160
4,344	4,948	5,591	6,273	6,995	7,755	8,556	9,395	10,274	11,191	12,149	13,145	14,181	15,256	16,370	17,524	18,716
76	81	86	91	96	101	106	111	116	121	126	131	136	141	146	151	156
4,536	5,153	5,809	6,504	7,238	8,012	8,825	9,677	10,568	11,499	12,469	13,478	14,527	15,615	16,742	17,908	19,113

M80	M85	M90	M95	M100	M105	M110	M115	M120	M125	M130	M135	M140	M145	M150	M155	M160
1,610	1,829	2,062	2,309	2,570	2,844	3,133	3,435	3,752	4,082	4,426	4,785	5,157	5,543	5,943	6,357	6,785
1,542	1,756	1,984	2,226	2,483	2,753	3,037	3,335	3,647	3,972	4,312	4,666	5,034	5,415	5,811	6,220	6,644
1,542	1,756	1,984	2,226	2,483	2,753	3,037	3,335	3,647	3,972	4,312	4,666	5,034	5,415	5,811	6,220	6,644

M80	M85	M90	M95	M100	M105	M110	M115	M120	M125	M130	M135	M140	M145	M150	M155	M160
2,087	2,370	2,672	2,992	3,330	3,685	4,059	4,451	4,861	5,290	5,736	6,200	6,682	7,183	7,701	8,238	8,792
1,998	2,276	2,571	2,885	3,217	3,567	3,935	4,321	4,726	5,147	5,588	6,046	6,523	7,017	7,530	8,060	8,609
1,998	2,276	2,571	2,885	3,217	3,567	3,935	4,321	4,726	5,147	5,588	6,046	6,523	7,017	7,530	8,060	8,609

M80	M85	M90	M95	M100	M105	M110	M115	M120	M125	M130	M135	M140	M145	M150	M155	M160
2,268	2,576	2,904	3,252	3,619	4,006	4,412	4,838	5,284	5,750	6,234	6,739	7,263	7,807	8,371	8,954	9,557
2,126	2,422	2,737	3,071	3,424	3,797	4,189	4,599	5,030	5,479	5,948	6,435	6,943	7,469	8,014	8,579	9,163
2,126	2,422	2,737	3,071	3,424	3,797	4,189	4,599	5,030	5,479	5,948	6,435	6,943	7,469	8,014	8,579	9,163

M80	M85	M90	M95	M100	M105	M110	M115	M120	M125	M130	M135	M140	M145	M150	M155	M160
3,266	3,710	4,182	4,683	5,212	5,769	6,354	6,967	7,609	8,279	8,978	9,704	10,459	11,242	12,054	12,894	13,762
2,814	3,206	3,622	4,064	4,532	5,025	5,544	6,087	6,657	7,251	7,872	8,517	9,189	9,885	10,607	11,355	12,128
2,814	3,206	3,622	4,064	4,532	5,025	5,544	6,087	6,657	7,251	7,872	8,517	9,189	9,885	10,607	11,355	12,128



Tie Rod Types

Eye Rods k_t 0.6

DSI355 – Anchor Force to DIN EN 1993-5			A150	A175	A200	A225	A250	A275	A300A	A300B	A325
			M39	M42	M48	M60	M64	M68	M72	M76	M80
Shaft Diameter	d	[mm]	36	39	42	45	48	52	56	60	64
Eye Thickness	c	[mm]	25	30	33	39	42	47	50	50	55
Eye Length	La	[mm]	86	106	127	135	147	166	190	190	210
Eye Width	a	[mm]	72	85	105	110	125	135	155	155	165
Pin, Diameter	d0	[mm]	30	33	36	40	47	52	56	56	62

ASF500 – Anchor Force to DIN EN 1993-5			A150	A175	A200	A225	A250	A275	A300A	A300B	A325
			M39	M42	M48	M60	M64	M68	M72	M76	M80
Shaft Diameter	d	[mm]	36	39	42	45	48	52	56	60	64
Eye Thickness	c	[mm]	25	30	33	39	42	47	50	50	55
Eye Length	La	[mm]	86	106	127	135	147	166	190	190	210
Eye Width	a	[mm]	72	85	105	110	125	135	155	155	165
Pin, Diameter	d0	[mm]	30	33	36	41	47	52	56	56	62

ASF720 – Anchor Force to DIN EN 1993-5			A150	A175	A200	A225	A250	A275	A300A	A300B	A325
			M39	M42	M48	M60	M64	M68	M72	M76	M80
Shaft Diameter	d	[mm]	36	39	42	45	48	52	56	60	64
Eye Thickness	c	[mm]	25	30	33	39	42	47	50	50	55
Eye Length	La	[mm]	86	106	127	135	147	166	190	190	210
Eye Width	a	[mm]	72	85	105	110	125	135	155	155	165
Pin, Diameter	d0	[mm]	30	33	40	44	50	55	61	61	66



A350	A375A	A375B	A400	A425	A450	A475	A500	A525	A550	A575	A600	A625	A650
M85	M90	M95	M100	M105	M115	M120	M125	M130	M135	M145	M150	M155	M160
68	72	75	80	85	90	95	100	105	110	115	120	125	130
60	63	63	66	72	75	80	85	90	95	100	105	115	120
220	235	235	253	290	300	323	340	350	365	373	380	439	459
180	190	190	210	230	240	255	270	275	290	300	310	330	340
68	70	70	76	80	85	90	95	100	100	105	110	115	120

A350	A375A	A375B	A400	A425	A450	A475	A500	A525	A550	A575	A600	A625	A650
M85	M90	M95	M100	M105	M115	M120	M125	M130	M135	M145	M150	M155	M160
68	72	75	80	85	90	95	100	105	110	115	120	125	130
60	63	63	66	72	75	80	85	90	95	100	105	115	120
220	235	235	253	290	300	323	340	350	365	373	380	439	459
180	190	190	210	230	240	255	270	275	290	300	310	330	340
68	70	70	76	80	85	90	95	100	105	110	115	120	125

A350	A375A	A375B	A400	A425	A450	A475	A500	A525	A550	A575	A600	A625	A650
M85	M90	M95	M100	M105	M115	M120	M125	M130	M135	M145	M150	M155	M160
68	72	75	80	85	90	95	100	105	110	115	120	125	130
60	63	63	66	72	75	80	85	90	95	100	105	115	120
220	235	235	253	290	300	323	340	350	365	373	380	439	459
180	190	190	210	230	240	255	270	275	290	300	310	330	340
72	76	76	85	90	95	100	105	110	110	115	125	130	135

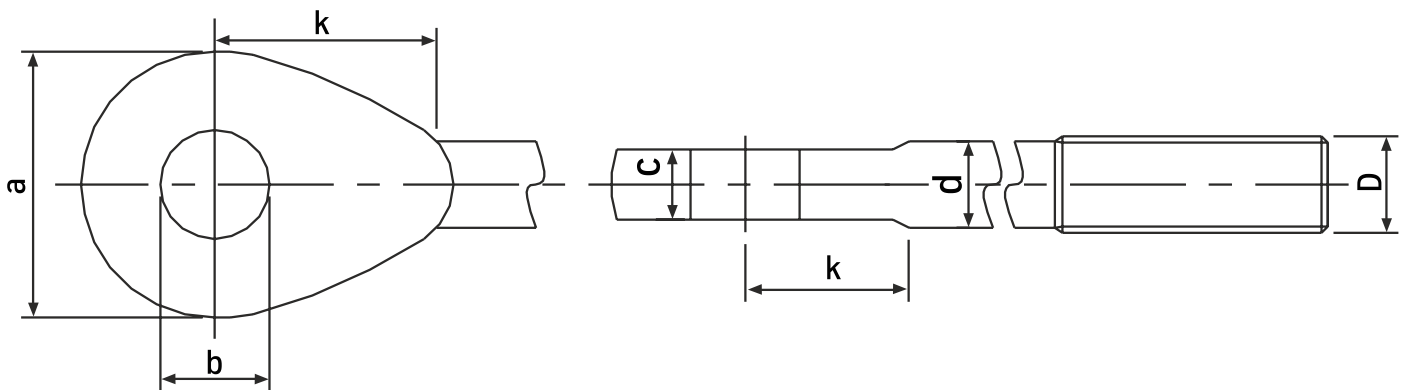

Tie Rod Connection Elements

Turnbuckles for Tie Rods

DSI 355 to EAU with k_t 0.55 | DSI 355 Anchor with k_t 0.6 in S355

Nominal Diameter	ØD_1	Metric	M39	M42	M45	M48	M52	M56	M60	M64	M68	M72	M76
Length	a	[mm]	350	400	400	450	450	450	500	500	500	500	550
Outside Diameter	b	[mm]	63.5	70	73	76.1	82.5	82.5	88.9	101.6	101.6	108	114.3
Thread Length	c	[mm]	40	45	45	50	55	60	60	65	70	75	80
Undercut	e	[mm]	42	45	48	51	55	59	63	67	71	75	79
Hole Diameter	f	[mm]	25	25	25	25	25	25	25	25	25	25	25
Weight		[kg]	5.4	7.7	8.1	9.7	11.4	10.2	13.3	19.2	17.6	20.0	24.7

DSI 460/500 to EAU with k_t 0.55 | DSI 460/500 Anchor with k_t 0.6 in S355 | Tie Rods DSI 355 to DSI 500 with k_t 0.9 in S355 in 20MnV6

Nominal Diameter	ØD_1	Metric	M39	M42	M45	M48	M52	M56	M60	M64	M68	M72	M76
Length	a	[mm]	350	400	400	450	450	450	500	500	500	500	550
Outside Diameter	b	[mm]	73	76.1	82.5	82.5	88.9	101.6	101.6	108	114.3	121	127
Thread Length	c	[mm]	40	45	45	50	55	60	60	65	70	75	80
Undercut	e	[mm]	42	45	48	51	55	59	63	67	71	75	79
Hole Diameter	f	[mm]	25	25	25	25	25	25	25	25	25	25	25
Weight		[kg]	8.2	9.9	11.8	12.5	14.4	19.9	20.7	23.3	26.0	29.2	35.1

DSI 720 on request

Couplers for Tie Rods

DSI 355 to EAU with k_t 0.55 | DSI 355 Anchor with k_t 0.6 in S355

Nominal Diameter	ØD_1	Metric	M39	M42	M45	M48	M52	M56	M60	M64	M68	M72	M76
Length	a	[mm]	120	130	140	150	150	170	180	180	190	200	210
Outside Diameter	b	[mm]	63.5	70	73	76.1	82.5	82.5	88.9	101.6	101.6	108	114.3
Hole Diameter	f	[mm]	25	25	25	25	25	25	25	25	25	25	25
Weight		[kg]	1.9	2.5	2.9	3.2	3.8	3.8	4.8	6.9	6.7	8.0	9.4

DSI 460/ 500 to EAU with k_t 0.55 | DSI 460/500 Anchor with k_t 0.6 in S355 | Tie Rods DSI 355 to DSI 500 with k_t 0.9 in 20MnV6

Nominal Diameter	ØD_1	Metric	M39	M42	M45	M48	M52	M56	M60	M64	M68	M72	M76
Length	a	[mm]	120	130	140	150	150	170	180	180	190	200	210
Outside Diameter	b	[mm]	73	76.1	82.5	82.5	88.9	101.6	101.6	108	114.3	121	127
Hole Diameter	f	[mm]	25	25	25	25	25	25	25	25	25	25	25
Weight		[kg]	2.8	3.2	4.1	4.2	4.8	7.5	7.5	8.4	9.9	11.7	13.4

DSI 720 on request

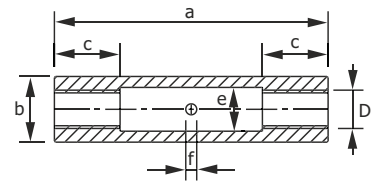
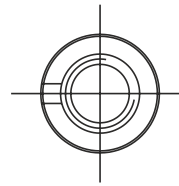
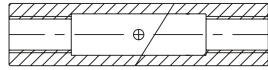

M80	M85	M90	M95	M100	M105	M110	M115	M120	M125	M130	M135	M140	M145	M150	M155	M160
550	550	550	550	550	550	550	550	550	550	550	550	550	550	550	550	550
114.3	121	127	133	139.7	152.4	152.4	159	165.1	177.8	177.8	191	193.7	203	216	216	219.1
80	85	90	95	100	105	110	115	120	125	130	135	140	145	150	155	160
83	88	93	98	103	108	113	118	123	128	133	138	143	148	153	158	163
25	25	25	25	25	25	25	25	25	25	25	25	25	25	25	25	25
22.6	25.1	27.2	29.4	32.3	41.4	37.7	40.9	43.6	54.2	49.9	61.9	60.8	68.4	81.9	76.7	76.0

M80	M85	M90	M95	M100	M105	M110	M115	M120	M125	M130	M135	M140	M145	M150	M155	M160
550	550	550	550	550	550	550	550	550	550	550	550	550	550	550	550	550
133	139.7	141.3	152.4	159	168.3	177.8	191	193.7	203	203	219.1	219.1	229	229	244.5	244.5
80	85	90	95	100	105	110	115	120	125	130	135	140	145	150	155	160
83	88	93	98	103	108	113	118	123	128	133	138	143	148	153	158	163
25	25	25	25	25	25	25	25	25	25	25	25	25	25	25	25	25
38.3	41.7	40.2	48.2	51.8	58.7	66.2	78.9	78.4	86.8	82.4	101.0	96.3	106.5	101.5	121.2	115.9

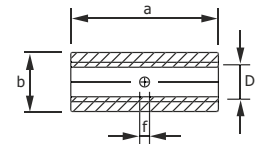
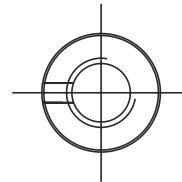
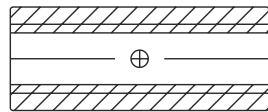

M80	M85	M90	M95	M100	M105	M110	M115	M120	M125	M130	M135	M140	M145	M150	M155	M160
225	240	250	260	260	260	260	260	260	260	260	270	280	290	300	310	320
114.3	121	127	133	139.7	152.4	152.4	159	165.1	177.8	177.8	191	193.7	203	216	216	219.1
25	25	25	25	25	25	25	25	25	25	25	25	25	25	25	25	25
9.2	11.0	12.4	13.9	15.3	19.6	17.8	19.3	20.6	25.6	23.6	30.4	30.9	36.1	44.7	43.3	44.2

M80	M85	M90	M95	M100	M105	M110	M115	M120	M125	M130	M135	M140	M145	M150	M155	M160
225	240	250	260	275	285	295	305	320	330	340	350	360	370	380	390	400
133	139.7	141.3	152.4	159	168.3	177.8	191	193.7	203	203	219.1	219.1	229	229	244.5	244.5
25	25	25	25	25	25	25	25	25	25	25	25	25	25	25	25	25
15.7	18.2	18.3	22.8	25.9	30.4	35.5	43.7	45.6	52.1	51.0	64.3	63.0	71.7	70.1	86.0	84.3

Tie Rod Connection Elements

Hinged Turnbuckles for Tie Rods

DSI 355 to EAU with k_t 0.55 and SF355 Anchor with k_t 0.6 in S355

Nominal Diameter	$\varnothing D_1$	Metric	M39	M42	M45	M48	M52	M56	M60	M64	M68	M72	M76
Length (Plate)	a	[mm]	510	530	540	545	555	570	615	630	640	650	765
Height (Plate)	b	[mm]	90	90	100	110	110	130	130	140	150	160	170
Thickness (Plate)	c	[mm]	15	15	20	20	20	20	25	25	25	25	30
Hole Spacing (Plate)	e	[mm]	400	410	410	410	410	410	450	450	450	450	550
Height (Nut)	f	[mm]	40	45	45	50	55	60	60	65	70	75	80
Width (Nut between Plates)	g	[mm]	60	65	70	75	80	85	90	95	100	105	110
Width (Nut and Plates)	h	[mm]	100	110	120	130	130	140	150	160	160	170	180
Weight		[kg]	10.8	11.2	17.0	18.8	19.2	23.3	31.4	34.6	37.7	40.8	61.3

DSI 460/500 to EAU with k_t 0.55, DSI 460/500 with k_t 0.6 and DSI 355 to DSI 500 with k_t 0.9 in S355

Nominal Diameter	$\varnothing D_1$	Metric	M39	M42	M45	M48	M52	M56	M60	M64	M68	M72	M76
Length (Plate)	a	[mm]	530	545	560	570	580	595	645	655	670	685	795
Height (Plate)	b	[mm]	100	110	120	130	130	150	150	160	170	180	190
Thickness (Plate)	c	[mm]	20	20	25	25	25	30	30	35	35	35	40
Hole Spacing (Plate)	e	[mm]	400	410	410	410	410	410	450	450	450	450	550
Height (Nut)	f	[mm]	40	45	45	50	55	60	60	65	70	75	80
Width (Nut between Plates)	g	[mm]	60	65	70	75	80	85	90	95	100	105	110
Width (Nut and Plates)	h	[mm]	110	120	130	140	140	160	160	180	180	190	200
Weight		[kg]	16.6	18,8	26,4	29,1	29,6	42,0	45,6	57,6	62,6	67,8	94,9

DSI 720 on request

Hexagonal Nuts*

DSI 355 to DSI 500 in S355 | DSI 720 in Class 10

Nominal Diameter	$\varnothing D_1$	Metric	M39	M42	M45	M48	M52	M56	M60	M64	M68	M72	M76
Width across flats	s	[mm]	60	65	70	75	80	85	90	95	100	105	110
Width across corners	a	[mm]	66	72	78	83	89	94	100	106	112	117	123
Height	m	[mm]	31	34	36	38	42	45	48	51	54	58	61
Weight		[kg]	0.5	1	0.8	1	1.2	1.4	2	2	2	2.6	3

* Dimensions to ISO 4032, class 5/8/10.

Constructional differences possible when using S355 as nut grade. Please contact our engineering department for information.

Domed Nuts*

DSI 355 to DSI 500 in S355 | DSI 720 in class 10

Nominal Diameter	$\varnothing D_1$	Metric	M39	M42	M45	M48	M52	M56	M60	M64	M68	M72	M76
Width Across Flats	s	[mm]	60	65	70	75	80	85	90	95	100	105	110
Width Across Corners	a	[mm]	66	72	78	83	89	94	100	106	112	117	123
Height	m	[mm]	31	34	36	38	42	45	48	51	54	58	61
Weight		[kg]	0.5	1	0.8	1	1.2	1.4	2	2	2	2.6	3

* Dimensions to ISO 4032, class 5/8/10.

Constructional differences possible when using S355 as nut grade.

Please contact our engineering department for information.

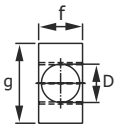
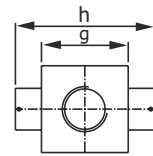
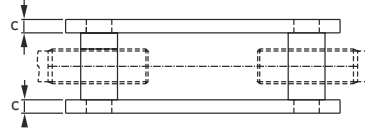
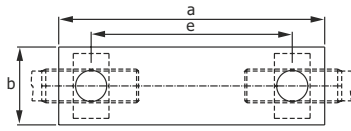

M80	M85	M90	M95	M100	M105	M110	M115	M120	M125	M130	M135	M140	M145	M150	M155	M160
775	790	840	860	865	875	880	880	900	900	915	935	945	960	975	990	1,005
180	190	200	210	220	230	240	250	270	280	290	300	310	320	330	350	360
30	30	35	35	40	40	40	40	45	45	50	50	50	55	55	60	60
550	550	590	590	580	580	570	560	560	550	550	550	550	550	550	550	550
80	85	90	95	100	105	110	115	120	125	130	135	140	145	150	155	160
115	120	130	135	145	150	155	165	170	180	185	190	200	210	210	220	230
190	190	210	220	240	240	250	260	270	280	300	300	310	330	330	350	360
65.7	70.7	92.3	99.2	119.5	126.4	132.6	138.2	171.7	178.0	208.3	220.2	230.0	265.3	277.8	326.4	340.8

M80	M85	M90	M95	M100	M105	M110	M115	M120	M125	M130	M135	M140	M145	M150	M155	M160
810	860	880	900	910	925	930	935	955	960	980	995	1,010	1,025	1,045	1,060	1,080
200	240	230	240	260	270	280	290	310	320	340	350	360	370	390	400	420
40	45	45	50	55	55	60	60	65	65	70	70	75	75	80	80	85
550	550	590	590	580	580	570	560	560	550	550	550	550	550	550	550	550
80	85	90	95	100	105	110	115	120	125	130	135	140	145	150	155	160
115	120	130	135	145	150	155	165	170	180	185	190	200	210	210	220	230
210	220	230	250	270	270	290	300	310	320	340	340	360	370	380	390	410
101.7	145.8	143.0	169.6	204.3	215.7	245.3	255.4	302.1	313.5	366.2	382.7	428.1	446.6	511.9	532.5	605.3

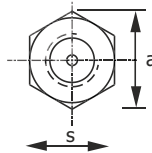
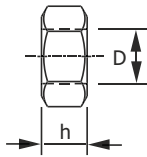

M80	M85	M90	M95	M100	M105	M110	M115	M120	M125	M130	M135	M140	M145	M150	M155	M160
115	120	130	135	145	150	155	165	170	180	185	190	200	210	210	220	230
128	134	145	151	162	168	173	185	190	202	207	212	224	235	235	245	255
64	68	72	76	80	84	88	92	96	100	104	108	112	116	120	124	128
3.4	3.9	4.9	5.6	6.8	7.5	8.2	10.1	11.7	13	13.8	15.2	17.5	20.7	20	23.1	26.5

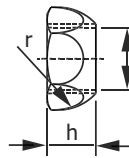
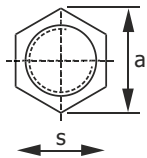

M80	M85	M90	M95	M100	M105	M110	M115	M120	M125	M130	M135	M140	M145	M150	M155	M160
115	120	130	135	145	150	155	165	170	180	185	190	200	210	210	220	230
128	134	145	151	162	168	173	185	190	202	207	212	224	235	235	245	255
64	68	72	76	80	84	88	92	96	100	104	108	112	116	120	124	128
3.4	3.9	4.9	5.6	6.8	8	8.2	10.1	11.7	13	13.8	15.2	17.5	20.7	20	23	27

Tie Rod Connection Elements

Shackle Joint for Tie Rods

DSI 355

Nominal Diameter	ØD ₁	Metric	A150	A175	A200	A225	A250	A275	A300A	A300B	A325
Length (Plate)	a	[mm]	195	220	255	270	310	340	380	380	405
Height (Plate)	b	[mm]	80	90	100	110	130	140	150	150	160
Thickness (Plate)	c	[mm]	15	15	20	20	25	25	25	30	30
Hole Spacing (Plate)	e	[mm]	90	105	130	135	150	165	190	190	200
Diameter (Pin)	g	[mm]	30	33	36	40	47	52	56	56	62
Length (Pin)	k	[mm]	90	95	110	120	135	140	145	160	160
Weight		[kg]	4.3	5.5	9.1	10.8	18	21.6	25.9	30.5	35.1

DSI 500

Nominal Diameter	ØD ₁	Metric	A150	A175	A200	A225	A250	A275	A300A	A300B	A325
Length (Plate)	a	[mm]	195	220	255	275	310	340	380	380	405
Height (Plate)	b	[mm]	80	90	100	110	130	140	150	150	160
Thickness (Plate)	c	[mm]	15	20	20	25	25	30	30	35	35
Hole Spacing (Plate)	e	[mm]	90	105	130	135	150	165	190	190	200
Diameter (Pin)	g	[mm]	30	33	36	41	47	52	56	56	62
Length (Pin)	k	[mm]	90	105	110	130	135	150	155	170	170
Weight		[kg]	4.3	7	9.1	13.4	18	25.3	30.4	35	40.1

DSI 720 on request

Rocker Plate for Tie Rods

DSI 355 to EAU with k_t 0.55 and DSI 355 Anchor with k_t 0.6 in S355

Nominal Diameter	ØD ₁	Metric	M39	M42	M45	M48	M52	M56	M60	M64	M68	M72	M76
Plate Width	b	[mm]	80	90	90	100	100	110	120	120	130	140	140
Plate Height	h	[mm]	70	80	80	90	90	100	110	110	120	120	130
Plate Thickness	t	[mm]	20	30	30	30	30	30	40	40	40	40	40
Rocker	s	[mm]	50	50	50	50	50	50	50	50	50	50	50
Weight		[kg]	1.1	1.8	1.8	2.2	2	2.5	3.8	3.7	4.4	4.5	4.9

Threaded Rocker Plate for Tie Rods

DSI 355 to EAU with k_t 0.55 and DSI 355 Anchor with k_t 0.6 in S355

Nominal Diameter	ØD ₁	Metric	M39	M42	M45	M48	M52	M56	M60	M64	M68	M72	M76
Plate Width	b	[mm]	100	110	110	120	130	150	150	150	160	160	180
Plate Height	h	[mm]	100	110	110	120	130	150	150	150	160	160	180
Plate Thickness	t	[mm]	35	40	40	45	45	50	55	60	65	65	70
Rocker	s	[mm]	50	50	50	50	50	50	50	50	50	50	50
Weight		[kg]	2.9	3.9	3.8	5	5.8	8.6	9.2	9.7	11.9	11.7	16.1

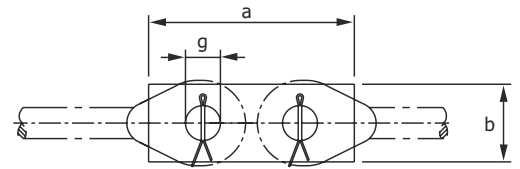
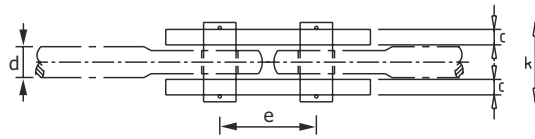

A350	A375A	A375B	A400	A425	A450	A475	A500	A525	A550	A575	A600	A625	A650
445	465	465	505	545	570	605	640	660	680	705	735	775	805
180	180	180	200	210	220	230	250	260	260	270	280	300	310
30	35	35	40	40	40	45	50	50	50	55	55	60	60
220	230	230	255	280	290	310	325	330	350	360	375	400	410
68	70	70	76	80	85	90	95	100	100	105	110	115	120
165	180	185	200	205	215	230	245	250	255	275	280	295	300
43.5	52.4	52.7	71.7	81.4	90.4	111.9	141.3	152.7	157.4	186.2	202.5	246.9	266.3

A350	A375A	A375B	A400	A425	A450	A475	A500	A525	A550	A575	A600	A625	A650
445	465	465	505	545	570	605	640	660	695	720	750	795	820
180	180	180	200	210	220	230	250	260	270	280	300	310	320
40	40	40	45	50	50	55	55	60	60	65	65	70	70
220	230	230	255	280	290	310	325	330	350	360	375	400	410
68	70	70	76	80	85	90	95	100	105	110	115	120	125
185	190	195	210	225	235	250	255	270	275	295	300	315	320
56	58.9	59.2	79.6	99.3	110	133.6	153.8	179.5	197.2	229.6	256.6	301.1	322.2

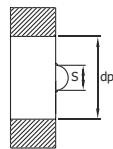
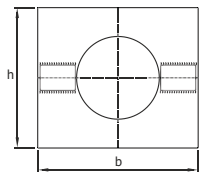

M80	M85	M90	M95	M100	M105	M110	M115	M120	M125	M130	M135	M140	M145	M150	M155	M160
150	160	180	180	190	200	210	220	230	240	250	260	270	280	290	300	310
130	140	150	150	160	170	180	190	190	200	210	220	230	240	240	250	250
40	50	50	50	50	60	60	60	60	70	70	70	70	80	80	90	90
60	60	60	60	60	60	60	60	60	60	60	60	60	60	60	60	60
5.4	7.8	9.6	9.2	10.3	14	15.5	17.1	17.2	21.7	23.7	25.8	28.6	34.4	35.3	42.5	43.5

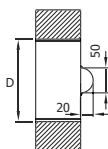
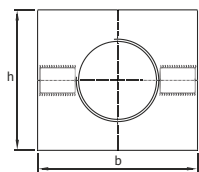

M80	M85	M90	M95	M100	M105	M110	M115	M120	M125	M130	M135	M140	M145	M150	M155	M160
180	180	200	200	220	220	220	230	240	250	260	280	280	300	300	320	320
180	180	200	200	220	220	220	230	240	250	260	280	280	300	300	320	320
80	80	85	95	100	105	110	115	120	130	140	150	150	150	150	160	160
60	60	60	60	60	60	60	60	60	60	60	60	60	60	60	60	60
18.3	17.8	23.7	25.7	33.2	34	34.8	39.7	44.9	52.6	61.1	77.1	75.7	88.3	86.8	106.7	105.1

Tie Rod Connection Elements

Universal Joints for Tie Rods

DSI 355 to EAU with k_t 0.55 and DSI 355 Anchor with k_t 0.6 in S355

Nominal Diameter	$\text{Ø}D_1$	Metric	M39	M42	M45	M48	M52	M56	M60	M64	M68	M72	M76
Length (Plate)	a	[mm]	195	220	235	265	275	290	305	330	350	365	405
Height and Width (Plate)	b	[mm]	90	90	100	110	110	130	130	140	150	160	170
Leg Thickness (Plate)	c	[mm]	14	15	16	17	18	20	21	23	24	25	27
Hole Spacing (Plate)	e	[mm]	105	120	125	150	150	155	160	175	190	190	220
Leg Length (Plate)	f	[mm]	91	103	110	124	129	135	142	154	163	170	189
Diameter (Pin)	g	[mm]	33	35	39	41	43	48	50	55	58	61	65
Length (Pin)	k	[mm]	90	95	100	105	110	120	125	130	140	145	150
Weight		[kg]	5.2	6.2	7.9	10.3	11.3	15.9	17.5	22	26.4	30.7	38.3

Universal Joints at Waling for Tie Rods

DSI 355 to EAU with k_t 0.55 and DSI 355 Anchor with k_t 0.6 in S355

Nominal Diameter	$\text{Ø}D_1$	Metric	M39	M42	M45	M48	M52	M56	M60	M64	M68	M72	M76
Length (Plate)	a	[mm]	Length to suit installation conditions										
Height and Width (Plate)	b	[mm]	90	90	100	110	110	130	130	140	150	160	170
Leg Thickness (Plate)	c	[mm]	14	15	16	17	18	20	21	23	24	25	27
Hole Spacing (Plate)	e	[mm]	Length to suit installation conditions										
Leg Length (Plate)	f	[mm]	91	103	110	124	129	135	142	154	163	170	189
Diameter (Pin)	g	[mm]	33	35	39	41	43	48	50	55	58	61	65
Length (Pin)	k	[mm]	90	95	100	105	110	120	125	130	140	145	150

DSI 720 on request.

Length (a) and hole spacing (e) for a universal joint at the waling to suit customer specification or type of installation.

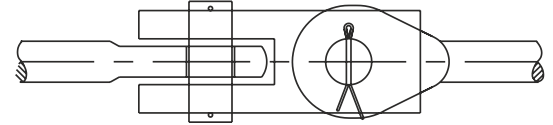
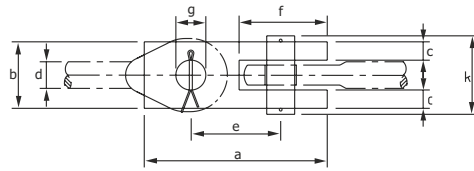

M80	M85	M90	M95	M100	M105	M110	M115	M120	M125	M130	M135	M140	M145	M150	M155	M160
425	435	475	500	545	580	595	615	655	680	705	740	755	785	815	860	890
180	190	200	210	220	230	240	250	270	280	290	300	310	320	330	350	360
28	30	32	34	36	37	39	40	42	44	46	48	50	52	55	57	58
230	230	255	265	295	320	320	330	355	365	380	400	400	415	430	460	470
199	203	222	233	255	272	278	288	307	318	330	346	353	367	380	402	416
68	73	77	82	87	91	95	99	104	108	113	118	122	126	131	136	141
160	165	175	185	195	200	210	215	225	235	245	255	260	270	280	290	300
44.2	51.3	62.3	73.6	88	100.3	113.8	125.7	151.4	171	191.8	217.4	237.8	264.9	299.2	345.4	376.5

M80	M85	M90	M95	M100	M105	M110	M115	M120	M125	M130	M135	M140	M145	M150	M155	M160
Length to suit installation conditions																
180	190	200	210	220	230	240	250	270	280	290	300	310	320	330	350	360
28	30	32	34	36	37	39	40	42	44	46	48	50	52	55	57	58
Length to suit installation conditions																
199	203	222	233	255	272	278	288	307	318	330	346	353	367	380	402	416
68	73	77	82	87	91	95	99	104	108	113	118	122	126	131	136	141
160	165	175	185	195	200	210	215	225	235	245	255	260	270	280	290	300



Tie Rod and Waling Joints

Rear Plate for DSI 355 Tie Rods acc. to 1993-5 with k_t 0.9 in S355

Type I Standard – Angle 0°

Nominal Diameter	ØD_1	Metric	M39	M42	M45	M48	M52	M56	M60	M64	M68	M72	M76
Gurtung			UNP180	UNP200	UNP200	UNP220	UNP240	UNP240	UNP260	UNP280	UNP300	UNP320	UNP320
Waling Spacing			80	80	80	80	80	80	100	100	100	100	100
Width	wp	[mm]	160	160	180	180	180	200	200	200	220	220	240
Height	hp	[mm]	140	140	140	140	140	140	160	160	160	160	160
Thickness	tp	[mm]	20	25	25	25	25	30	30	30	30	30	30
Hole Diameter	Ød	[mm]	45	48	51	54	58	62	66	70	74	78	82

Type II Conical/Off-Centered – Angle up to max. 10°

Nominal Diameter	ØD_1	Metric	M39	M42	M45	M48	M52	M56	M60	M64	M68	M72	M76
Gurtung			UNP180	UNP200	UNP200	UNP220	UNP240	UNP240	UNP260	UNP280	UNP300	UNP320	UNP320
Waling Spacing			100	100	120	120	120	140	140	160	160	180	180
Width	wp	[mm]	160	160	180	180	180	200	200	200	220	220	240
Height	hp	[mm]	160	160	180	180	180	200	200	220	220	240	240
Thickness	tp	[mm]	20	25	25	25	25	30	35	40	40	45	45
Hole Diameter	Ød	[mm]	48	51	55	59	64	68	73	78	83	88	93

Type III Conical/Centered – Angle up to max. 5°

Nominal Diameter	ØD_1	Metric	M39	M42	M45	M48	M52	M56	M60	M64	M68	M72	M76
Gurtung			UNP180	UNP200	UNP200	UNP220	UNP240	UNP240	UNP260	UNP280	UNP300	UNP320	UNP320
Waling Spacing			100	100	120	120	120	140	140	140	160	160	180
Width	wp	[mm]	160	160	180	180	180	200	200	200	220	220	240
Height	hp	[mm]	160	160	180	180	180	200	200	200	220	220	240
Thickness	tp	[mm]	20	20	25	25	25	30	35	35	40	40	45
Hole Diameter	Ød	[mm]	45	48	51	54	58	62	67	71	76	80	84

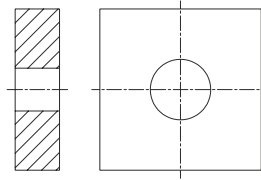

M80	M85	M90	M95	M100	M105	M110	M115	M120	M125	M130	M135	M140	M145	M150	M155	M160
UNP350	UNP380	UNP400	UNP400	HEB340	HEB360	HEB400	HEB450	HEB450	HEB500	HEB550	HEB550	HEB600	HEB600	HEB650	HEB650	HEB700
100	120	120	120	140	140	140	140	140	160	160	160	160	180	180	180	180
240	240	260	280	280	280	280	300	320	340	340	340	360	360	380	380	400
160	180	180	180	200	200	200	200	200	220	220	220	220	240	240	240	240
35	40	40	45	45	45	45	45	50	50	55	55	55	60	60	65	65
86	91	96	101	106	111	116	121	126	131	136	141	146	151	156	161	166

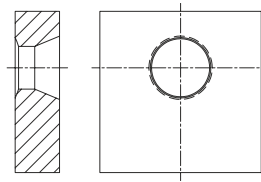

M80	M85	M90	M95	M100	M105	M110	M115	M120	M125	M130	M135	M140	M145	M150	M155	M160
UNP350	UNP380	UNP400	UNP400	HEB340	HEB360	HEB400	HEB450	HEB450	HEB500	HEB550	HEB550	HEB600	HEB600	HEB650	HEB650	HEB700
180	200	220	220	220	240	260	270	280	300	310	330	340	360	380	400	420
240	240	260	280	280	280	280	300	320	340	340	340	360	360	380	380	400
240	260	280	280	280	300	320	330	340	360	370	390	400	420	440	460	480
45	55	55	55	60	70	70	75	80	85	90	100	105	105	110	120	125
98	104	110	116	122	128	134	140	146	152	158	164	170	176	182	188	195

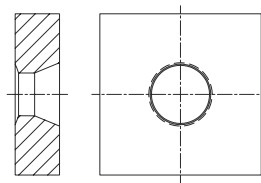
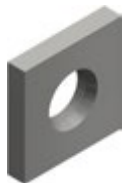

M80	M85	M90	M95	M100	M105	M110	M115	M120	M125	M130	M135	M140	M145	M150	M155	M160
UNP350	UNP380	UNP400	UNP400	HEB340	HEB360	HEB400	HEB450	HEB450	HEB500	HEB550	HEB550	HEB600	HEB600	HEB650	HEB650	HEB700
180	180	200	220	220	220	220	240	260	280	280	280	300	300	320	320	340
240	240	260	280	280	280	280	300	320	340	340	340	360	360	380	380	400
240	240	260	280	280	280	280	300	320	340	340	340	360	360	380	380	400
45	50	50	55	60	65	65	70	75	80	85	90	95	95	100	105	110
89	94	100	105	111	116	122	128	133	139	144	150	155	161	166	172	177

Tie Rod and Waling Joints

Rear Plate for DSI 460 Tie Rods acc. to 1993-5 with k_t 0.9 in S355

Type I Standard – Angle 0°

Nominal Diameter	ØD_1	Metric	M39	M42	M45	M48	M52	M56	M60	M64	M68	M72	M76
Gurtung			UNP180	UNP200	UNP200	UNP220	UNP240	UNP240	UNP260	UNP280	UNP300	UNP320	UNP320
Waling Spacing			80	80	80	80	80	80	100	100	100	100	100
Width	wp	[mm]	160	160	180	180	180	200	200	200	220	220	240
Height	hp	[mm]	140	140	140	140	140	140	160	160	160	160	160
Thickness	tp	[mm]	25	30	35	35	35	40	40	40	40	40	40
Hole Diameter	Ød	[mm]	45	48	51	54	58	62	66	70	74	78	82

Type II Conical/Off-Centered – Angle up to max. 10°

Nominal Diameter	ØD_1	Metric	M39	M42	M45	M48	M52	M56	M60	M64	M68	M72	M76
Gurtung			UNP180	UNP200	UNP200	UNP220	UNP240	UNP240	UNP260	UNP280	UNP300	UNP320	UNP320
Waling Spacing			100	100	120	120	120	140	140	160	160	180	180
Width	wp	[mm]	160	160	180	180	180	200	200	200	220	220	240
Height	hp	[mm]	160	160	180	180	180	200	200	220	220	240	240
Thickness	tp	[mm]	25	30	35	35	35	40	45	50	50	55	55
Hole Diameter	Ød	[mm]	46	50	53	57	61	66	71	75	80	85	89

Type III Conical/Centered – Angle up to max. 5°

Nominal Diameter	ØD_1	Metric	M39	M42	M45	M48	M52	M56	M60	M64	M68	M72	M76
Gurtung			UNP180	UNP200	UNP200	UNP220	UNP240	UNP240	UNP260	UNP280	UNP300	UNP320	UNP320
Waling Spacing			100	100	120	120	120	140	140	140	160	160	180
Width	wp	[mm]	160	160	180	180	180	200	200	200	220	220	240
Height	hp	[mm]	160	160	180	180	180	200	200	200	220	220	240
Thickness	tp	[mm]	25	30	35	35	35	40	45	45	50	50	55
Hole Diameter	Ød	[mm]	45	48	51	54	58	62	67	71	76	80	84

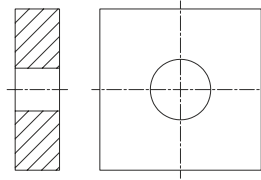

M80	M85	M90	M95	M100	M105	M110	M115	M120	M125	M130	M135	M140	M145	M150	M155	M160
UNP350	UNP380	UNP400	UNP400	HEB340	HEB360	HEB400	HEB450	HEB450	HEB500	HEB550	HEB550	HEB600	HEB600	HEB650	HEB650	HEB700
100	120	120	120	140	140	140	140	140	160	160	160	160	180	180	180	180
240	240	260	280	280	280	280	300	320	340	340	340	360	360	380	380	400
160	180	180	180	200	200	200	200	200	220	220	220	220	240	240	240	240
45	50	50	60	60	65	65	65	70	70	75	75	75	80	80	85	85
86	91	96	101	106	111	116	121	126	131	136	141	146	151	156	161	166

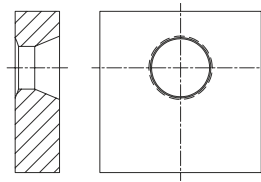

M80	M85	M90	M95	M100	M105	M110	M115	M120	M125	M130	M135	M140	M145	M150	M155	M160
UNP350	UNP380	UNP400	UNP400	HEB340	HEB360	HEB400	HEB450	HEB450	HEB500	HEB550	HEB550	HEB600	HEB600	HEB650	HEB650	HEB700
180	200	220	220	220	240	260	270	280	300	310	330	340	360	380	400	420
240	240	260	280	280	280	280	300	320	340	340	340	360	360	380	380	400
240	260	280	280	280	300	320	330	340	360	370	390	400	420	440	460	480
60	70	70	70	75	90	95	95	100	105	115	125	130	130	135	150	155
94	100	106	112	118	123	129	135	141	147	153	159	164	170	176	182	188

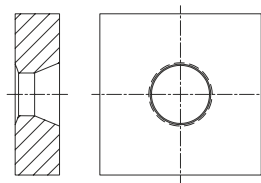

M80	M85	M90	M95	M100	M105	M110	M115	M120	M125	M130	M135	M140	M145	M150	M155	M160
UNP350	UNP380	UNP400	UNP400	HEB340	HEB360	HEB400	HEB450	HEB450	HEB500	HEB550	HEB550	HEB600	HEB600	HEB650	HEB650	HEB700
180	180	200	220	220	220	220	240	260	280	280	280	300	300	320	320	340
240	240	260	280	280	280	280	300	320	340	340	340	360	360	380	380	400
240	240	260	280	280	280	280	300	320	340	340	340	360	360	380	380	400
60	65	65	70	75	85	85	90	95	100	110	115	120	120	125	135	140
89	94	100	105	111	116	122	128	133	139	144	150	155	161	166	172	177

Tie Rod and Waling Joints

Rear Plate for DSI 500 Tie Rods acc. to 1993-5 with k_t 0.9 in S355

Type I Standard – Angle 0°

Nominal Diameter	ØD_1	Metric	M39	M42	M45	M48	M52	M56	M60	M64	M68	M72	M76
Gurtung			UNP220	UNP220	UNP240	UNP240	UNP260	UNP280	UNP300	UNP320	UNP320	UNP350	UNP380
Waling Spacing			80	80	80	80	80	80	100	100	100	100	100
Width	wp	[mm]	160	160	180	180	180	200	200	200	220	220	240
Height	hp	[mm]	140	140	140	140	140	140	160	160	160	160	160
Thickness	tp	[mm]	25	30	35	35	35	40	40	40	40	40	40
Hole Diameter	Ød	[mm]	45	48	51	54	58	62	66	70	74	78	82

Type II Conical/Off-Centered – Angle up to max. 10°

Nominal Diameter	ØD_1	Metric	M39	M42	M45	M48	M52	M56	M60	M64	M68	M72	M76
Gurtung			UNP220	UNP220	UNP240	UNP240	UNP260	UNP280	UNP300	UNP320	UNP320	UNP350	UNP380
Waling Spacing			100	100	120	120	120	140	140	160	160	180	180
Width	wp	[mm]	160	160	180	180	180	200	200	200	220	220	240
Height	hp	[mm]	160	160	180	180	180	200	200	220	220	240	240
Thickness	tp	[mm]	25	30	35	35	35	40	45	50	50	55	55
Hole Diameter	Ød	[mm]	46	50	53	57	61	66	71	75	80	85	89

Type III Conical/Centered – Angle up to max. 5°

Nominal Diameter	ØD_1	Metric	M39	M42	M45	M48	M52	M56	M60	M64	M68	M72	M76
Gurtung			UNP220	UNP220	UNP240	UNP240	UNP260	UNP280	UNP300	UNP320	UNP320	UNP350	UNP380
Waling Spacing			100	100	120	120	120	140	140	140	160	160	180
Width	wp	[mm]	160	160	180	180	180	200	200	200	220	220	240
Height	hp	[mm]	160	160	180	180	180	200	200	200	220	220	240
Thickness	tp	[mm]	25	30	35	35	35	40	45	45	50	50	55
Hole Diameter	Ød	[mm]	45	48	51	54	58	62	67	71	76	80	84

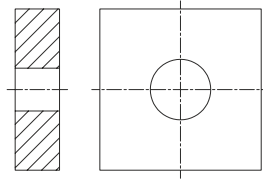

M80	M85	M90	M95	M100	M105	M110	M115	M120	M125	M130	M135	M140	M145	M150	M155	M160
UNP400	HEB340	HEB360	HEB400	HEB450	HEB450	HEB500	HEB550	HEB550	HEB600	HEB650	HEB700	HEB700	HEB800	HEB800	HEB900	HEB900
100	120	120	120	140	140	140	140	140	160	160	160	160	180	180	180	180
240	240	260	280	280	280	280	300	320	340	340	340	360	360	380	380	400
160	180	180	180	200	200	200	200	200	220	220	220	220	240	240	240	240
45	50	50	60	60	65	65	65	70	70	75	75	75	80	80	85	85
86	91	96	101	106	111	116	121	126	131	136	141	146	151	156	161	166

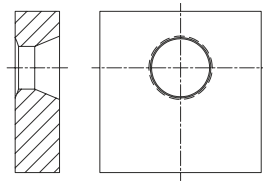

M80	M85	M90	M95	M100	M105	M110	M115	M120	M125	M130	M135	M140	M145	M150	M155	M160
UNP400	HEB340	HEB360	HEB400	HEB450	HEB450	HEB500	HEB550	HEB550	HEB600	HEB650	HEB700	HEB700	HEB800	HEB800	HEB900	HEB900
180	200	220	220	220	240	260	270	280	300	310	330	340	360	380	400	420
240	240	260	280	280	280	280	300	320	340	340	340	360	360	380	380	400
240	260	280	280	280	300	320	330	340	360	370	390	400	420	440	460	480
60	70	70	70	75	90	95	95	100	105	115	125	130	130	135	150	155
94	100	106	112	118	123	129	135	141	147	153	159	164	170	176	182	188

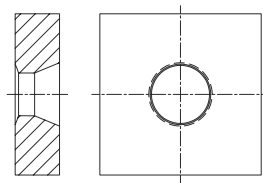
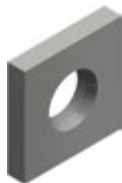

M80	M85	M90	M95	M100	M105	M110	M115	M120	M125	M130	M135	M140	M145	M150	M155	M160
UNP400	HEB340	HEB360	HEB400	HEB450	HEB450	HEB500	HEB550	HEB550	HEB600	HEB650	HEB700	HEB700	HEB800	HEB800	HEB900	HEB900
180	180	200	220	220	220	220	240	260	280	280	280	300	300	320	320	340
240	240	260	280	280	280	280	300	320	340	340	340	360	360	380	380	400
240	240	260	280	280	280	280	300	320	340	340	340	360	360	380	380	400
60	65	65	70	75	85	85	90	95	100	110	115	120	120	125	135	140
89	94	100	105	111	116	122	128	133	139	144	150	155	161	166	172	177

Tie Rod and Waling Joints

Rear Plate for DSI 720 Tie Rods

Type I Standard – Angle 0°

Nominal Diameter	ØD ₁	Metric	M39	M42	M45	M48	M52	M56	M60	M64	M68	M72	M76
Gurtung			UNP260	UNP280	UNP280	UNP300	UNP320	UNP350	UNP380	UNP400	HEB340	HEB360	HEB400
Waling Spacing			80	80	80	80	80	80	100	100	100	100	100
Width	wp	[mm]	160	160	180	180	180	200	200	200	220	220	240
Height	hp	[mm]	140	140	140	140	140	140	160	160	160	160	160
Thickness	tp	[mm]	35	40	40	45	45	50	50	50	55	55	55
Hole Diameter	Ød	[mm]	45	48	51	54	58	62	66	70	74	78	82

Type II Conical/Off-Centered – Angle up to max. 10°

Nominal Diameter	ØD ₁	Metric	M39	M42	M45	M48	M52	M56	M60	M64	M68	M72	M76
Gurtung			UNP260	UNP280	UNP280	UNP300	UNP320	UNP350	UNP380	UNP400	HEB340	HEB360	HEB400
Waling Spacing			100	100	120	120	120	140	140	160	160	180	180
Width	wp	[mm]	160	160	180	180	180	200	200	200	220	220	240
Height	hp	[mm]	160	160	180	180	180	200	200	220	220	240	240
Thickness	tp	[mm]	35	35	40	40	45	50	60	65	65	70	70
Hole Diameter	Ød	[mm]	45	49	52	56	60	65	69	74	79	83	88

Type III Conical/Centered – Angle up to max. 5°

Nominal Diameter	ØD ₁	Metric	M39	M42	M45	M48	M52	M56	M60	M64	M68	M72	M76
Gurtung			UNP260	UNP280	UNP280	UNP300	UNP320	UNP350	UNP380	UNP400	HEB340	HEB360	HEB400
Waling Spacing			100	100	120	120	120	140	140	140	160	160	180
Width	wp	[mm]	160	160	180	180	180	200	200	200	220	220	240
Height	hp	[mm]	160	160	180	180	180	200	200	200	220	220	240
Thickness	tp	[mm]	35	35	40	40	45	50	60	60	65	65	70
Hole Diameter	Ød	[mm]	45	48	51	54	58	62	67	71	76	80	84

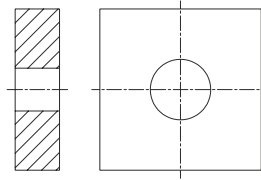

M80	M85	M90	M95	M100	M105	M110	M115	M120	M125	M130	M135	M140	M145	M150	M155	M160
HEB400	HEB450	HEB500	HEB550	HEB550	HEB550	HEB550	HEB600	HEB650	HEB700	HEB700	HEB800	HEB800	HEB900	HEB900	HEB1000	HEB1000
100	120	120	120	140	140	140	140	140	160	160	160	160	180	180	180	180
240	240	260	280	280	280	280	300	320	340	340	340	360	360	380	380	400
160	180	180	180	200	200	200	200	200	220	220	220	220	240	240	240	240
60	70	70	75	80	80	85	85	90	90	95	95	100	105	110	110	115
86	91	96	101	106	111	116	121	126	131	136	141	146	151	156	161	166

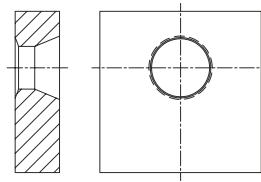

M80	M85	M90	M95	M100	M105	M110	M115	M120	M125	M130	M135	M140	M145	M150	M155	M160
HEB400	HEB450	HEB500	HEB550	HEB550	HEB550	HEB550	HEB600	HEB650	HEB700	HEB700	HEB800	HEB800	HEB900	HEB900	HEB1000	HEB1000
180	200	220	220	220	240	260	270	280	300	310	330	340	360	380	400	420
240	240	260	280	280	280	280	300	320	340	340	340	360	360	380	380	400
240	260	280	280	280	300	320	330	340	360	370	390	400	420	440	460	480
75	75	80	90	95	105	110	120	125	130	135	155	160	165	170	185	190
92	98	104	110	115	121	127	133	138	144	150	156	162	167	173	179	185

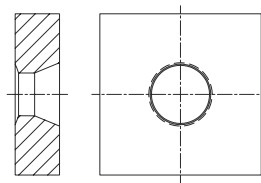
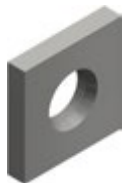

M80	M85	M90	M95	M100	M105	M110	M115	M120	M125	M130	M135	M140	M145	M150	M155	M160
HEB400	HEB450	HEB500	HEB550	HEB550	HEB550	HEB550	HEB600	HEB650	HEB700	HEB700	HEB800	HEB800	HEB900	HEB900	HEB1000	HEB1000
180	180	200	220	220	220	220	240	260	280	280	280	300	300	320	320	340
240	240	260	280	280	280	280	300	320	340	340	340	360	360	380	380	400
240	240	260	280	280	280	280	300	320	340	340	340	360	360	380	380	400
70	75	80	90	95	100	100	110	120	125	130	140	150	150	155	165	175
89	94	100	105	111	116	122	128	133	139	144	150	155	161	166	172	177

Tie Rod and Waling Joints

T-Connections for Tie Rods*

DSI 355

Nominal Diameter	ØD ₁	Metric	A150	A175	A200	A225	A250	A275	A300A	A300B	A325
Width, Longitudinal Plate	b1	[mm]	80	90	100	110	130	140	150	150	160
Thickness, Longitudinal Plate	t1	[mm]	15	15	20	20	25	25	25	30	30
Length, Transverse Plate	l2	[mm]	200	230	250	280	330	350	380	380	400
Width, Transverse Plate	b2	[mm]	80	90	100	110	130	140	150	150	160
Thickness, Transverse Plate	t2	[mm]	10	10	10	15	15	15	15	15	20
Hole Diameter	ØD	[mm]	32	35	38	42	49	54	58	58	64
Hole Spacing	e	[mm]	55	60	65	70	80	90	95	95	105

DSI 500

Nominal Diameter	ØD ₁	Metric	A150	A175	A200	A225	A250	A275	A300A	A300B	A325
Width, Longitudinal Plate	b1	[mm]	80	90	100	110	130	140	150	150	160
Thickness, Longitudinal Plate	t1	[mm]	15	20	20	25	25	30	30	35	35
Length, Transverse Plate	l2	[mm]	200	230	250	280	330	350	380	380	400
Width, Transverse Plate	b2	[mm]	80	90	100	110	130	140	150	150	160
Thickness, Transverse Plate	t2	[mm]	10	10	15	15	20	20	20	25	25
Hole Diameter	ØD	[mm]	32	35	38	43	49	54	58	58	64
Hole Spacing	e	[mm]	55	60	65	70	80	90	95	95	105

DSI 720 on request

T-Connections in Combined Sheet Piling for Anchors*

DSI 355

Nominal Diameter	ØD ₁	Metric	A150	A175	A200	A225	A250	A275	A300A	A300B	A325
Width, Longitudinal Plates	b1	[mm]	80	90	110	120	130	150	160	160	170
Thickness, Longitudinal Plates	t1	[mm]	20	20	25	25	30	35	35	40	40
Width, Rear Plate	b2	[mm]	150	170	200	230	260	280	320	320	340
Height, Rear Plate	l2	[mm]	150	170	200	230	260	280	320	320	340
Thickness, Rear Plate	t2	[mm]	20	25	30	35	40	45	55	50	55
Hole Diameter	ØD1	[mm]	32	35	42	46	52	57	63	63	68

* Weld seams are not shown but information can be supplied and they are included in the calculations. The weld seams actually required depend on the calculations carried out by the design office.

All dimensions are based on axial loads in the principal direction. Situations with inclined loads, bending or torsion depend on the detailed calculations carried out by the design office.

Dimensions do not include an allowance for corrosion; such detailed calculations must be carried out by the design office.

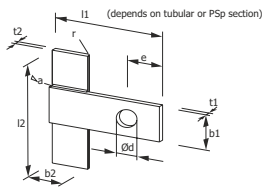

A350	A375A	A375B	A400	A425	A450	A475	A500	A525	A550	A575	A600	A625	A650
180	180	180	200	210	220	230	250	260	260	270	280	300	310
35	35	35	40	40	45	45	50	50	50	55	55	60	60
450	450	450	500	530	550	580	630	650	650	680	700	750	780
180	180	180	200	210	220	230	250	260	260	270	280	300	310
20	20	20	20	25	25	25	30	30	30	35	35	35	35
70	72	72	78	82	87	92	97	102	102	107	112	117	122
115	120	120	125	135	140	150	160	165	165	175	180	190	200

A350	A375A	A375B	A400	A425	A450	A475	A500	A525	A550	A575	A600	A625	A650
180	180	180	200	210	220	230	250	260	270	280	300	310	320
40	40	45	45	50	50	55	55	60	60	65	65	70	70
450	450	450	500	530	550	580	630	650	680	700	750	780	800
180	180	180	200	210	220	230	250	260	270	280	300	310	320
25	25	30	30	30	35	35	40	40	40	45	45	45	50
70	72	72	78	82	87	92	97	102	107	112	117	122	127
115	120	120	125	135	140	150	160	165	175	180	190	200	205

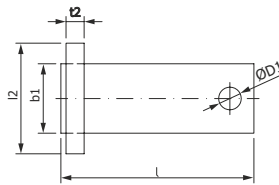
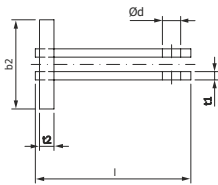

A350	A375A	A375B	A400	A425	A450	A475	A500	A525	A550	A575	A600	A625	A650
190	200	200	220	230	250	260	270	280	280	300	320	330	350
45	45	45	50	55	55	60	65	65	65	70	75	75	80
370	390	390	420	450	480	500	530	550	560	590	620	650	670
370	390	390	420	450	480	500	530	550	560	590	620	650	670
60	65	65	70	75	80	85	85	90	95	100	105	110	115
74	78	78	87	92	97	102	107	112	112	117	127	132	137

Typical Complete Tie Rod Systems

Compensate for Shallow Angles of up to max. 5°

Components

- Spherical Collar Nut
- End Plate with Spherical Recess
- Anchor Thread-Thread
- Turnbuckle
- Anchor Thread-Thread
- End plate with Spherical Recess
- Spherical Collar Nut

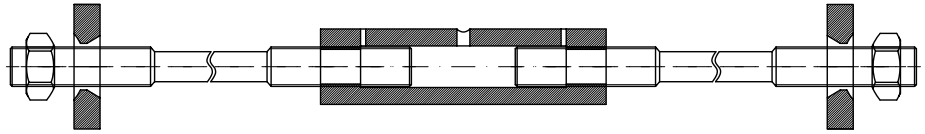

Dead Man

Components

- Nut
- Rear Plate
- Anchor Thread-Thread
- Turnbuckle
- Anchor Thread-Thread
- Rear Plate
- Nut

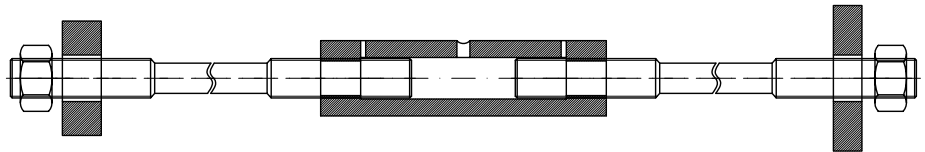

Combined Sheet Piling with Tubular Piles

Components

- Tube
- Plate
- Nut
- Eye Rod
- Shackle Joint
- Eye Rod
- Turnbuckle
- Anchor Thread-Thread
- End Plate with Spherical Recess
- Spherical Collar Nut

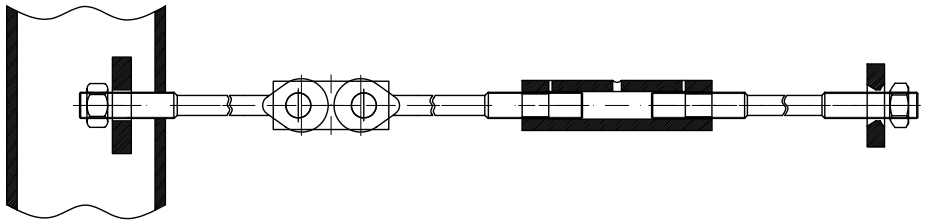

Combined Sheet Piling when using Grade DSI 720

Components

- Tube
- Plate
- Nut
- Eye Rod
- Shackle Joint Turnbuckle
- Anchor Thread-Thread
- Turnbuckle
- Anchor Thread-Thread
- Plate
- Nut

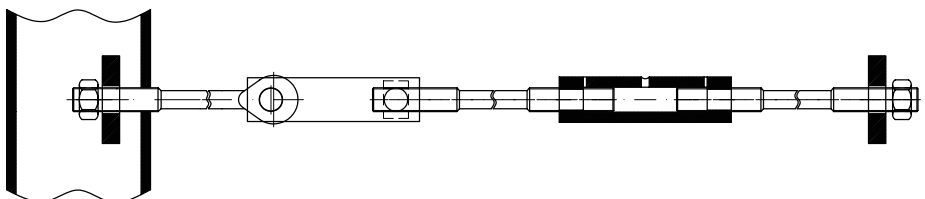

Typical Complete Tie Rod Systems

Anchors Connected to Tubular Piles

Components

- Tube
- T-Connection
- Eye Rod
- Turnbuckle
- Anchor Thread-Thread
- Coupler
- Anchor Thread-Thread
- End Plate with Spherical Recess
- Spherical Collar Nut

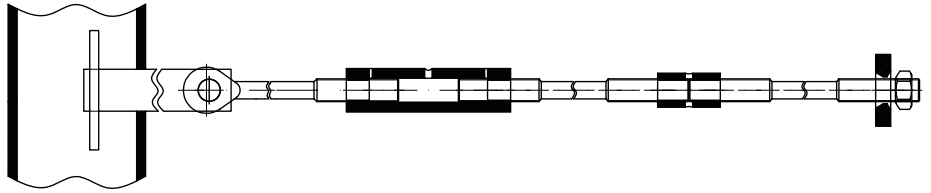

Heavy-Duty Walls with Steel Sections

Components

- HZ Section
- T-Connection
- Eye Rod
- Turnbuckle
- Anchor Thread-Thread
- Coupler
- Anchor Thread-Thread
- End Plate with Spherical Recess
- Spherical Collar Nut

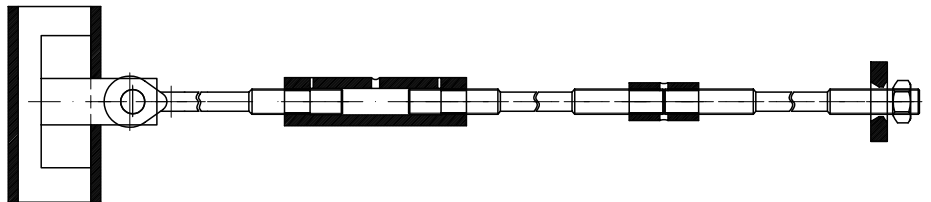

Alternative Tubular Pile Connection Option Permitting Rotational Movement in all Directions

Components

- Tube
- Plate
- Nut
- Anchor Thread-Thread
- Ball Fitting
- Anchor with Head for Ball Fitting
- Turnbuckle
- Anchor Thread-Thread
- Plate
- Nut

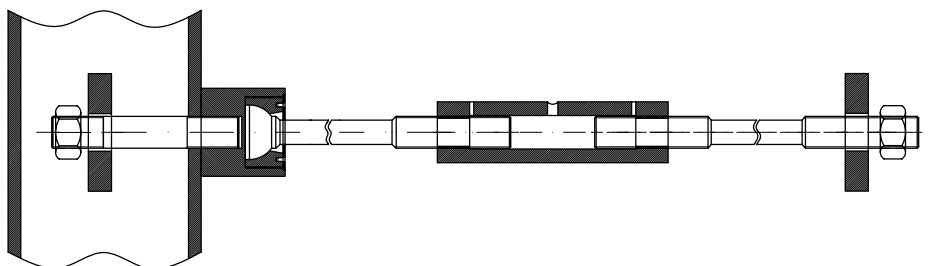

Walings

The waling system function typically is to transfer the loads from the sheet pile wall to the tie rods. Additionally the waling system aligns and stiffens the sheet pile wall. In general the waling system is located inside the main shoring wall. For a waling beam usually two latticed steel channels are used. Common steel profiles therefor are UPE or UNP types but also single LARSEN or I-sections can be used. The spacing between two waling steel profiles

depend on the tie rod diameter as well as the inclination of the tie rods and are generated by the use of additional welded on web plates.

Waling beam segments usually have a length equal to a multiple of the anchor spacing. Splice joints of the waling beams should be positioned in areas of minimum stress. This reduces the splicing costs to a minimum which means that the load capacity of the

splicing is just equal to the internal forces which occur at this point of the structure.

Our splice joints are prefabricated in a way that only one side of the waling beam has predrilled holes and the other side can be adapted according to the site conditions. Another opportunity is to use welded joint connections where no prefabrication is required.

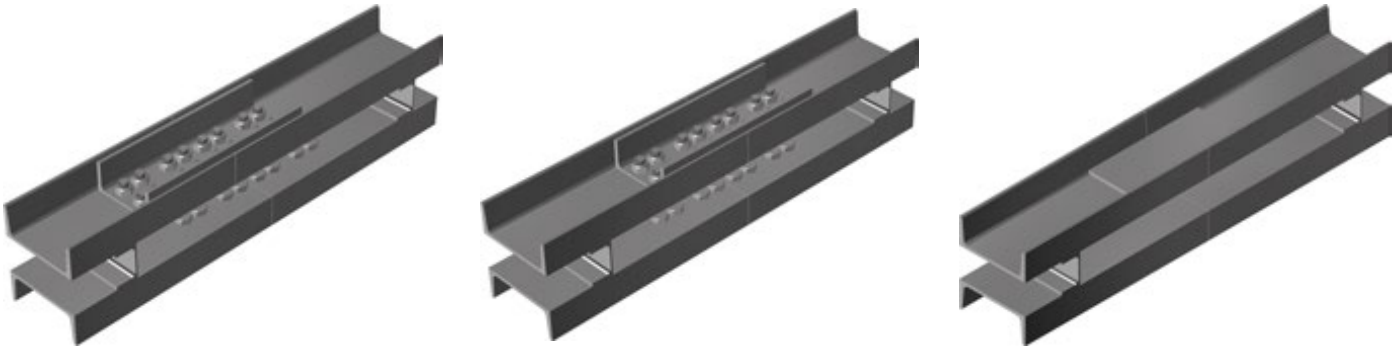

Waling Splice Joint

][Waling		Splicing piece][Dimensions							Bolts, DIN 933			Nut	Washer	Weight [kg]
	Wy [kg]/m][[kg]	a	b	c	e Ø	f	g	h	No.	Size	L	DIN 934	DIN 125	
	[cm ²]																	
UNP180	300	44	UNP120	560	14.9	37.5	45	67.5	22	40	60	80	32	M20	45	Ø37/ Ø21 x 3	M20	8
UNP200	382	50.6	UNP140	640	20.5	40	60	70	22	40	60	120	32	M20	45	Ø37/ Ø21 x 3	M20	8
UNP220	490	58.8	UNP160	680	25.7	40	80	70	22	40	60	140	32	M20	45	Ø37/ Ø21 x 3	M20	8
UNP240	600	66.4	UNP180	740	32.6	45	90	75	26	50	75	120	32	M24	50	Ø44/ Ø25 x 4	M24	13
UNP260	742	75.8	UNP200	800	40.5	45	110	75	26	50	75	150	32	M24	50	Ø44/ Ø25 x 4	M24	13
UNP280	892	83.8	UNP220	840	49.4	50	120	80	26	50	90	140	40	M24	55	Ø44/ Ø25 x 4	M24	16
UNP300	1,070	92.4	UNP220	920	54.1	50	120	90	26	50	90	180	40	M24	55	Ø44/ Ø25 x 4	M24	16
UNP320	1,360	119	UNP240	1,000	66.4	55	130	95	32	60	110	160	40	M30	65	Ø56/ Ø31 x 4	M30	35
UNP350	1,468	121.2	UNP260	1,000	75.8	60	140	105	32	60	110	160	40	M30	65	Ø56/ Ø31 x 4	M30	35
UNP380	1,660	126.2	UNP300	1,000	92.2	60	180	100	32	60	90	200	48	M30	65	Ø56/ Ø31 x 4	M30	42
UNP400	2,040	143.6	UNP300	1,000	92.2	60	180	110	32	60	90	200	48	M30	65	Ø56/ Ø31 x 4	M30	42
UPE180	301	39.5	UPE120	560	13.6	37.5	45	67.5	22	40	60	80	32	M20	45	Ø37/ Ø21 x 3	M20	8
UPE200	382	45.6	UPE140	640	18.6	40	60	70	22	40	60	120	32	M20	45	Ø37/ Ø21 x 3	M20	8
UPE220	488	53.2	UPE160	680	23.2	40	80	70	22	40	60	140	32	M20	45	Ø37/ Ø21 x 3	M20	8
UPE240	600	60.5	UPE180	740	29.2	45	90	75	26	50	75	120	32	M24	50	Ø44/ Ø25 x 4	M24	13
UPE270	780	70.4	UPE200	840	38.3	45	110	80	26	50	90	140	40	M24	55	Ø44/ Ø25 x 4	M24	16
UPE300	1,043	88.9	UPE220	920	49	50	120	90	26	50	90	180	40	M24	55	Ø44/ Ø25 x 4	M24	16
UPE330	1,335	106.4	UPE240	1,000	60.5	55	130	100	32	60	110	160	40	M30	65	Ø56/ Ø31 x 4	M30	35
UPE360	1,648	122.4	UPE270	1,000	70.4	65	140	110	32	60	110	160	40	M30	65	Ø56/ Ø31 x 4	M30	35
UPE400	2,098	144.4	UPE300	1,000	88.9	60	180	110	32	60	90	200	48	M30	65	Ø56/ Ø31 x 4	M30	42

Steel grade: S235JR / S355

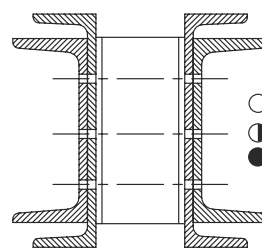
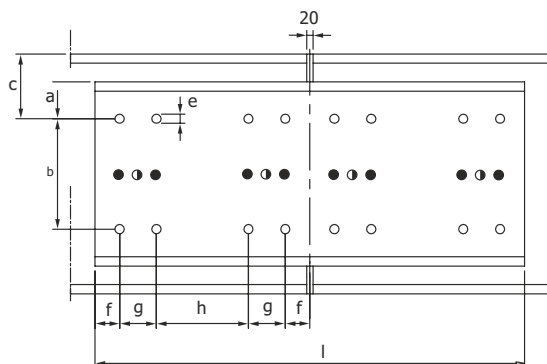

-][UNP180 to UNP400 + UPE180 to UPE400
- ◐ additional for][UNP280 to UNP350 + UPE270 to 360
- additional for][UNP380 to UNP400 + UPE400

Walings

Waling Bracket

Waling Section][180][200][220][240][260][280][300][320][350][380][400
h	[mm]	230	250	270	290	310	330	350	370	400	430	450
b	[mm]	230	250	270	290	310	330	350	370	400	430	450
	[kg]	2.89	3.34	3.83	4.35	4.90	5.48	6.09	6.73	7.76	8.85	9.62

Steel grade: S235JR / S355

Other forms made from channel sections are possible.

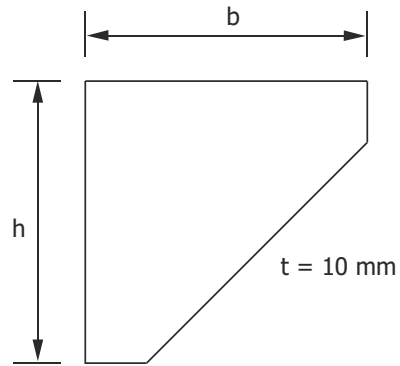

Waling Bolt with Head and Nut

D	Metric	M27	M33	M39	M45	M52	M56	M64	M72	M76	M85	M90
I[200	l [mm]	320	320	340	360							
	lg [mm]	85	95	105	115							
	[kg]	1.54	2.50	3.88	5.61							
I[220	l [mm]	340	340	360	380	400						
	lg [mm]	85	95	105	115	125						
	[kg]	1.62	2.62	4.05	5.83	8.21						
I[240	l [mm]	360	360	380	400	420	420	440	460			
	lg [mm]	85	95	105	115	125	130	135	140			
	[kg]	1.70	2.73	4.22	6.06	8.51	10.06	13.67	18.08			
I[260	l [mm]	380	380	400	420	440	440	460	480	500	510	530
	lg [mm]	85	95	105	115	125	130	135	140	145	150	155
	[kg]	1.77	2.85	4.39	6.29	8.80	10.41	14.11	18.65	22.72	28.88	34.24
I[280	l [mm]	400	400	420	440	460	460	480	500	520	530	550
	lg [mm]	85	95	105	115	125	130	135	140	145	150	155
	[kg]	1.85	2.97	4.56	6.52	9.10	10.76	14.56	19.23	23.36	29.69	35.16
I[300	l [mm]		420	440	460	480	480	500	520	540	550	570
	lg [mm]		95	105	115	125	130	135	140	145	150	155
	[kg]		3.09	4.73	6.75	9.39	11.10	15	19.80	24	30.50	36.07
I[320	l [mm]		440	460	480	500	500	520	540	560	570	590
	lg [mm]		95	105	115	125	130	135	140	145	150	155
	[kg]		3.21	4.89	6.97	9.69	11.45	15.44	20.32	24.64	31.31	36.98
I[350	l [mm]			490	510	530	530	550	570	590	600	620
	lg [mm]			105	115	125	130	135	140	145	150	155
	[kg]			5.15	7.32	10.13	11.97	16.11	21.22	25.60	32.53	38.35
I[380	l [mm]			520	540	560	560	580	600	620	630	650
	lg [mm]			105	115	125	130	135	140	145	150	155
	[kg]			5.40	7.66	10.58	12.49	16.78	22.08	26.56	33.74	39.72
I[400	l [mm]			540	560	580	580	600	620	640	650	670
	lg [mm]			105	115	125	130	135	140	145	150	155
	[kg]			5.57	7.89	10.88	12.84	17.22	22.65	27.20	34.58	40.63

Steel grade: S355 / S355J2+N

The weight includes the nut

Also available in ASF500 / 8.8 / 10.9

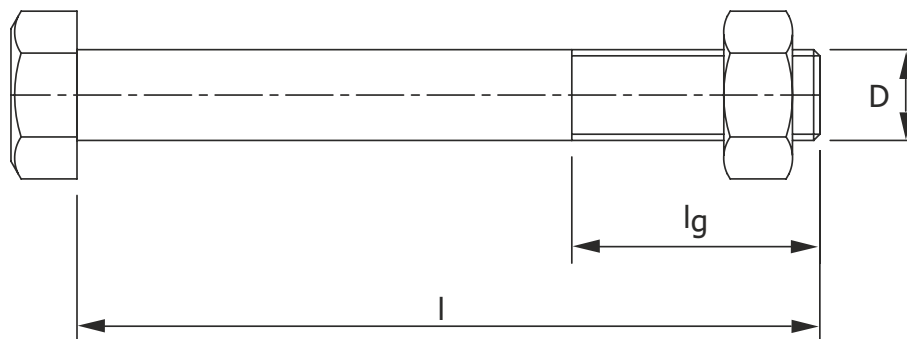

Waling Stud with two Nuts

D	Metric	M27	M33	M39	M45	M52	M56	M64	M72	M76	M85	M90
]] 200	l [mm]	350	380	400	440							
	lg [mm]	85	95	105	115							
	[kg]	1.65	2.86	4.38	6.42							
]] 220	l [mm]	380	410	430	460	480						
	lg [mm]	85	95	105	115	125						
	[kg]	1.77	3.03	4.63	6.65	9.31						
]] 240	l [mm]	390	420	440	470	510	510	530	560	580	600	630
	lg [mm]	85	95	105	115	125	130	135	140	145	150	155
	[kg]	1.81	3.09	4.72	6.76	9.75	11.64	15.57	20.77	24.34	31.88	37.93
]] 260	l [mm]	410	440	460	490	530	530	550	580	600	620	650
	lg [mm]	85	95	105	115	125	130	135	140	145	150	155
	[kg]	1.88	3.21	4.89	6.99	10.05	11.98	16.01	21.34	24.98	32.68	38.84
]] 280	l [mm]	430	460	480	510	550	550	570	600	620	640	670
	lg [mm]	85	95	105	115	125	130	135	140	145	150	155
	[kg]	1.96	3.33	5.06	7.22	10.35	12.33	16.96	21.91	25.62	33.49	39.76
]] 300	l [mm]		480	510	540	570	570	600	620	640	660	690
	lg [mm]		95	105	115	125	130	135	140	145	150	155
	[kg]		3.45	5.31	7.56	10.64	12.68	17.12	22.48	26.26	34.80	40.67
]] 320	l [mm]			530	560	590	590	620	640	660	680	710
	lg [mm]			105	115	125	130	135	140	145	150	155
	[kg]			5.48	7.79	10.94	13.02	17.57	23.05	26.90	35.11	41.58
]] 350	l [mm]			550	580	620	620	640	660	680	710	740
	lg [mm]			105	115	125	130	135	140	145	150	155
	[kg]			5.65	8.02	11.38	13.54	18.01	23.62	27.54	36.33	42.95
]] 380	l [mm]			580	610	650	650	670	680	710	740	770
	lg [mm]			105	115	125	130	135	140	145	150	155
	[kg]			5.90	8.36	11.83	14.06	18.68	24.19	28.50	37.54	44.32
]] 400	l [mm]			600	630	670	670	690	700	730	760	790
	lg [mm]			105	115	125	130	135	140	145	150	155
	[kg]			6.07	8.59	12.12	14.41	19.12	24.76	29.14	38.35	45.23

Steel grade: S355 / S355J2+N
 The weight includes the nut
 Also available in ASF500 / 8.8 / 10.9

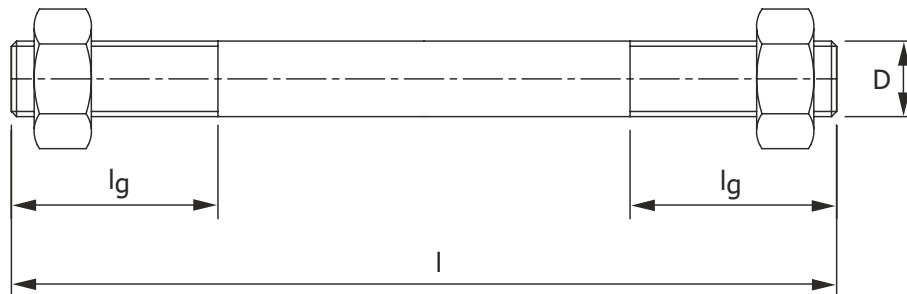

List of Standards and Directives

Standard	Date	Characteristics
DIN 976-1	2002-12	Stud bolts – Part 1: Metric thread
DIN 19703	2014-06	Locks for waterways for inland navigation – Principles for dimensioning and equipment
DIN 1054	2010-12	Subsoil – Verification of the safety of earthworks and foundations – Supplementary rules to DIN EN 1997-1
DIN EN 1090-1	2012-02	Execution of steel structures and aluminium structures Part 1: Requirements for conformity assessment of structural components
DIN EN 1090-2	2011-10	Execution of steel structures and aluminium structures Part 2: Technical requirements for steel structures
DIN 1478	2005-09	Turnbuckles made from steel tubes or round steel bars
DIN EN 1561	2012-01	Founding – Grey cast irons
DIN EN 1563	2012-03	Founding – Spheroidal graphite cast irons
DIN EN 1993-1-1	2010-12	Eurocode 3: Design of steel structures Part 1-1: General rules and rules for buildings
DIN EN 1993-1-1/NA	2010-12	National Annex – Nationally Determined Parameters Eurocode 3: Design of steel structures Part 1-1: General rules and rules for buildings
DIN EN 1993-1-5	2010-12	Eurocode 3: Design of steel structures – Part 1-5: Plated structural elements
DIN EN 1993-1-5/NA	2010-12	National Annex – Nationally Determined Parameters Eurocode 3: Design of steel structures Part 1-5: Plated structural elements
DIN EN 10025-2	2005-04	Hot-rolled products of structural steels Part 2: Technical delivery conditions for non-alloy structural steels
DIN EN 10027-1	2005-10	Designation systems for steels – Part 1: Steel names
DIN EN 10059	2004-02	Hot-rolled square steel bars for general purposes – Dimensions and tolerances on shape and dimensions
DIN EN 10060	2004-02	Hot-rolled round steel bars – Dimensions and tolerances on shape and dimensions
DIN EN 10061	2004-02	Hot-rolled hexagon steel bars – Dimensions and tolerances on shape and dimensions
DIN EN 10279	2000-03	Hot-rolled steel channels – Tolerances on shape, dimensions and mass
DIN 19704-1	2012-05	Hydraulic steel structures – Part 1: Criteria for design and calculation
DIN 19704-2	1998-05	Hydraulic steel structures – Part 2: Design and manufacturing
DIN EN ISO 4016	2011-06	Hexagon head bolts – Product grade C
DIN EN ISO 8062-3	2008-09	Geometrical Product Specifications (GPS) – Dimensional and geometrical tolerances for moulded parts Part 3: General dimensional and geometrical tolerances and machining allowances for castings
DIN EN ISO 9001	2008-12	Quality management systems – Requirements
DIN EN ISO 9013	2003-07	Thermal cutting – Classification of thermal cuts – Geometrical product specification and quality tolerances
EAU2012	2004-12	Recommendations of the Committee for Waterfront Structures, Harbours and Waterways, EAU 2012
BS OHSAS 18001	2007	Occupational health and safety management systems – Requirements
DIN EN ISO 12944-1	1998-07	Paints and varnishes – Corrosion protection of steel structures by protective paint systems Part 2: Classification of environments
DIN EN ISO 3834-2	2006-03	Quality requirements for fusion welding of metallic materials Part 2: Comprehensive quality requirements
DIN EN 1993-5	2009-12	Eurocode 3: Design of steel structures – Part 5: Piling
DIN EN 1997-1	2014-03	Eurocode 7: Geotechnical design – Part 1: General rules
DIN EN 10025-6	2011-04	Hot-rolled products of structural steels – Part 6: Technical delivery conditions for flat products of high yield strength structural steels in the quenched and tempered conditions

Austria
DSI Underground Austria GmbH
Alfred-Wagner-Strasse 1
4061 Pasching/Linz
Austria
Phone +43-7229-610 49-0
E-mail info.austria@dsiunderground.at
www.dsiunderground.at

Belgium
DYWIDAG-Systems International N.V.
Philipssite 5, bus 15
Ubicenter
3001 Leuven
Belgium
Phone +32-16-60 77 60
E-mail info.be@dywidag-systems.com
www.dywidag-systems.com/emea

France
DSI France SAS
Rue de la Craz
Z.I. des Chartinières
01120 Dagneux
France
Phone +33-4-78 79 27 82
E-mail dsi.france@dywidag-systems.fr
www.dywidag-systems.fr

Germany
DYWIDAG-Systems International GmbH
Germanenstrasse 8
86343 Koenigsbrunn
Germany
Phone +49-8231-96 07-0
E-mail geotechnik@dywidag-systems.com
www.dywidag-systems.de

Italy
DYWIT S.P.A.
Viale Europa 72 Strada A 7/9
20090 Cusago (Milano)
Italy
Phone +39-02-901 65 71
E-mail info@dywit.it
www.dywit.it

Netherlands
DYWIDAG-Systems International B.V.
Veilingweg 2
5301 KM Zaltbommel
Netherlands
Phone +31-418-57 89 22
E-mail email.nl@dywidag-systems.com
www.dywidag-systems.nl

Poland
DYWIDAG-Systems International Sp. z o.o.
ul. Bojowników o Wolność i Demokrację, 38/121
41-506 Chorzów
Poland
Phone +48-32-241 09 98
E-mail dsi-polska@dywidag-systems.com
www.dywidag-systems.pl

Please Note:

This brochure serves basic information purposes only. Technical data and information provided herein shall be considered non-binding and may be subject to change without notice. We do not assume any liability for losses or damages attributed to the use of this technical data and any improper use of our products. Should you require further information on particular products, please do not hesitate to contact us.

Portugal
DYWIDAG SISTEMAS CONSTRUCTIVOS, SA
Rua D. Manuel, n.º 24 A
Quinta da Parreirinha
2695-003 Bobadela (Loures)
Portugal
Phone +351-21-892 28 90
E-mail dywidag@dywidag-sistemas.com
www.dywidag-systems.pt

Spain
DYWIDAG SISTEMAS CONSTRUCTIVOS, S.A.
Avd/de la Industria, 4
Pol. Ind. la Cantuena
28947 Fuenlabrada (Madrid)
Spain
Phone +34-91-642 20 72
E-mail dywidag@dywidag-sistemas.com
www.dywidag-sistemas.com

United Kingdom
DYWIDAG-Systems International Ltd.
Northfield Road
Southam, Warwickshire, CV47 0FG
Great Britain
Phone +44-1926-81 39 80
E-mail sales@dywidag.co.uk
www.dywidag.co.uk

China
DYWIDAG-Systems International Far East Ltd.
9/F, Prosperity Millennia Plaza, Unit 905-907
663 King's Road, North Point
Hong Kong
Phone +852-28-33 19 13
E-mail dsihk@dsife.com.hk
www.dywidag-systems.com/emea

India
DSI-BRIDGECON Pvt. Ltd.
265, Okhla Industrial Estate, Phase 3
110020 New Delhi
India
Phone +974-44-58 04 11
E-mail info@dsi-bridgecon.com
www.dsi-bridgecon.com

Korea
DYWIDAG-Systems Korea Co. Ltd.
5th Floor, Spring Morning B/D
8, Mabang-ro, Seocho-gu
Seoul 137-894
Korea
Phone +82-2-34 72 01 41
E-mail dywidagkor@gmail.com
www.dsikorea.co.kr

Qatar
DYWIDAG-Systems Middle East W.L.L.
Al Shoumoukh Towers 11th Floor
Street 231 Building no 58
Area no 23, Suhaim Bin Hamed Doha
P.O.Box 24893
Doha / Qatar
Phone +974-44-58 04 11
E-mail info.qatar@dsi-middleeast.com
www.dsi-middleeast.com

Saudi Arabia
DYWIDAG-Systems Int. Saudi Arabia, LLC
P.O. Box 64014
Riyadh-Olaya 11536
Saudi Arabia
Phone +966-11-455 3123
E-mail dsihv@dywidag-systems.com
www.dywidag-systems.com/emea

ARGENTINA
AUSTRALIA
AUSTRIA
BELGIUM
BOSNIA AND HERZEGOVINA
BRAZIL
CANADA
CHILE
CHINA
COLOMBIA
COSTA RICA
CROATIA
CZECH REPUBLIC
DENMARK
EGYPT
ESTONIA
FINLAND
FRANCE
GERMANY
GREECE
GUATEMALA
HONDURAS
HONG KONG
INDIA
INDONESIA
IRAN
ITALY
JAPAN
KOREA
LEBANON
LUXEMBOURG
MALAYSIA
MEXICO
NETHERLANDS
NIGERIA
NORWAY
OMAN
PANAMA
PARAGUAY
PERU
POLAND
PORTUGAL
QATAR
RUSSIA
SAUDI ARABIA
SINGAPORE
SOUTH AFRICA
SPAIN
SWEDEN
SWITZERLAND
TAIWAN
THAILAND
TURKEY
UNITED ARAB EMIRATES
UNITED KINGDOM
URUGUAY
USA
VENEZUELA

www.dywidag-systems.com/emea